



CONCEALED
FASTENER
ROOF AND WALL
SYSTEMS

Installation Manual

1" NS-100 NAIL STRIP PANEL

NS-100

NAIL STRIP

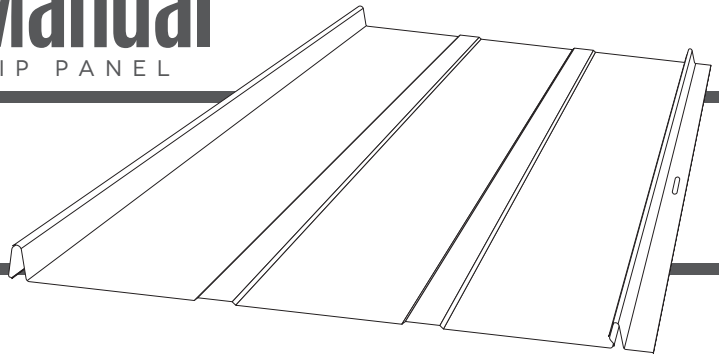

San Antonio • 2707 Castrovilla Rd • San Antonio, TX 78237 • (210) 227-727 McAllen • 2221 Austin Ave • McAllen, TX 78501 • (956) 627-2966
Dallas • 11569 Goodnight Ln • Dallas, TX 75229 • (972) 331 6800 Houston • 6460 Langfield Road • Houston, TX 77092 • (713) 944-4480

www.saqualitymetals.com



CONCEALED
FASTENER
ROOF AND WALL
SYSTEMS

NS-100
NAIL STRIP

IMPORTANT NOTICE

THIS MANUAL CONTAINS SUGGESTIONS AND GUIDELINES ON HOW TO INSTALL THE NS-100 NAIL STRIP PANEL AND TRIM DETAILS MANUFACTURED BY QUALITY METALS. THE CONTENTS OF THIS MANUAL REFLECT THE GUIDELINES IN EFFECT AT THE TIME OF ITS ORIGINAL PUBLICATION. QUALITY METALS RESERVES THE RIGHT TO MODIFY SPECIFICATIONS AND/OR DESIGNS WITHOUT OBLIGATION, IN RESPONSE TO EVOLVING CODE REQUIREMENTS. TO ENSURE ACCESS TO THE LATEST INFORMATION, PLEASE CONSULT OUR WEBSITE OR CONTACT US DIRECTLY.

APPLICATION AND DESIGN DETAILS PROVIDED HEREIN ARE FOR ILLUSTRATIVE PURPOSES ONLY AND MAY NOT BE SUITABLE FOR ALL ENVIRONMENTAL CONDITIONS OR BUILDING DESIGNS. PROJECTS SHOULD BE ENGINEERED AND INSTALLED IN ACCORDANCE WITH APPLICABLE BUILDING CODES, REGULATIONS, AND ACCEPTED INDUSTRY PRACTICES.

BEFORE COMMENCING INSTALLATION OF THE QUALITY METALS NS-100 ROOFING SYSTEM, THOROUGHLY REVIEW THIS MANUAL.

PRIOR TO INSTALLATION, INSPECT EACH PANEL AND ACCESSORY CAREFULLY. DO NOT INSTALL ANY QUALITY METALS PRODUCT THAT IS DAMAGED.

PLEASE NOTIFY QUALITY METALS IMMEDIATELY IF ANY PRODUCT DOES NOT MEET SPECIFICATIONS OR HAS BEEN DAMAGED.



Quality Metals © ALL RIGHTS RESERVED 2023.

INTRODUCTION

The **NS-100** Concealed System is an architectural panel designed for non-structural applications, featuring a snap-together installation method. This product incorporates a clip-less integral interlocking system, allowing panels to be installed in a single direction from a designated starting point.

The **NS-100** panel offers the leak resistance and aesthetic appeal characteristic of traditional standing seam systems, while eliminating the cost and complexity associated with seams. The clip-less system, in conjunction with screw attachments, facilitates thermal expansion and contraction, ensuring ease of panel movement with temperature fluctuations.

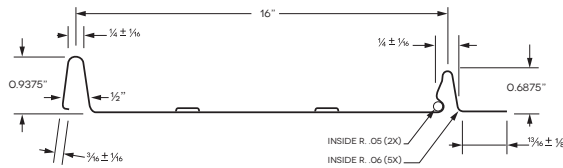

APPLICATIONS

Low-profile concealed fastening roof system suitable for residential and light commercial applications. This system features a low profile for simplified installation and offers symmetrical visual aesthetics, presenting a non-directional appearance.

SPECIFICATIONS

Gauges: 24 (standard), 22 and 26 (optional)
Coatings: Galvalume[®], Storm Armor (Durapon 70[®], Ceranamel[®]).
Substructure: Plywood or OSB to be a nominal 5/8 inch thick.

WIDTHS

Actual Panel Coverage (Width): 12" to 24"
Minimum Slope = 3 1/2":12"

LENGTHS

The **NS-100** Panels are offered in standard lengths ranging from 4' to 40'. Extended lengths beyond 40' necessitate supplementary handling, packaging, and shipping considerations, potentially incurring an additional handling charge. Continuous roll-formed lengths obviate the necessity for panel lap joints.

DESIGN

The **NS-100** panel features a completely concealed fastener roofing system, ensuring a sleek and durable solution for your roofing needs. With its low-maintenance requirements and ease of installation, the **NS-100** panel is suitable for both new construction and re-roofing projects, providing versatility and reliability for any application.

TESTING

UL-790 Fire Test of Roof Coverings, Class A,B, C.
UL-2218 For impact Resistance Class4.
UL 580 Uplift Resistance Class 90.

INSTALLATION

Solid plywood or OSB substrate is essential for installation. The **NS-100** panel features a clip-less system. With its snap-seam design, field seaming is not necessary. Please note that a Weathertight Warranty is not provided. Underlayment is required for optimal performance.

OIL CANNING

Offset, striations, and pencil ribs enhance structural integrity while minimizing the occurrence of oil canning.

TOOLS AND EQUIPMENT

The installer must possess previous experience and proficiency in working with metal roofing, including familiarity with the tools listed below and their respective applications.

- Caulking Gun
- Snips
- Cordless Screw Gun
- Pop Rivet Tool
- Tape Measure
- Hemming Tool
- Electrical Extension Cord
- Heavy Gloves
- Safety Glasses.

MECHANICAL HANDLING

FORKLIFT

A forklift may be utilized for panels up to 20 feet in length. Ensure that the forks are fully extended to their maximum separation. Avoid transporting open crates. When moving crates over uneven terrain or for extended distances, supplementary support for the panel load is necessary.

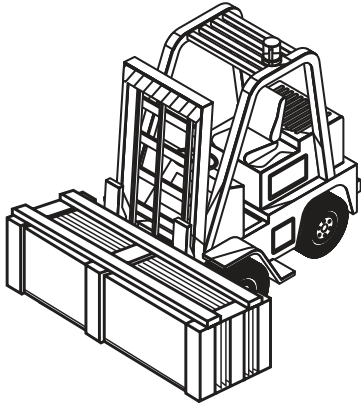

CRANE

A crane is recommended for hoisting panels exceeding 20 feet in length. Utilize a spreader bar to ensure uniform weight distribution across the lifting points. As a general guideline, avoid leaving more than one-third of the panel length unsupported during lifting operations. Use canvas or nylon slings for panel hoisting. Avoid the use of cables or chains as they may cause damage to the panels.

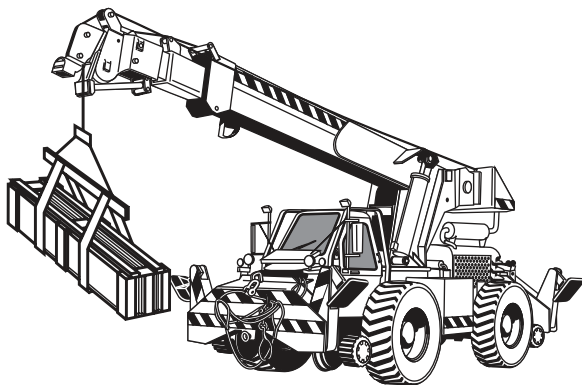

CAUTION

IMPROPER LOADING AND UNLOADING OF CRATES MAY LEAD TO BODILY HARM AND/OR MATERIAL DAMAGE. QUALITY METALS BEARS NO RESPONSIBILITY FOR ANY BODILY INJURIES OR MATERIAL DAMAGES RESULTING FROM IMPROPER LOADING AND UNLOADING PRACTICES.

GENERAL HANDLING

Each crate requires careful handling to avoid damage, ensuring the prevention of panel bending or finish abrasion. Follow these guidelines for proper care during crate unloading and handling to mitigate panel damage:

1. Crates must remain intact during handling until individual panels within each bundle are ready for installation.
2. Never lift crates by the banding.
3. Lift each crate as close to its center of gravity as possible. When lifting crates with a crane, use a spreader bar of appropriate length and nylon band slings.
4. Avoid using wire rope slings to prevent panel damage.
5. Depending on panel length, some crates may be lifted by a forklift. Ensure the forks are spread apart to their maximum spacing, and the load is centered on the forks to prevent scratching adjacent panels.
6. Avoid lifting panels by their ends; instead, lift them along their longitudinal edge in a vertical position.
7. For panels exceeding 10 feet in length, enlist two or more individuals to lift the panel along the same edge.
8. After opening crates, handle individual panels with care to prevent buckling or coating damage. When removing a panel from a crate, avoid sliding it over another panel. Instead, "roll" the individual panels out of the crate to minimize the risk of damage.

MANUAL HANDLING

It is imperative to wear soft gloves while handling panels. Panels should never be lifted by their ends. Instead, lift the panel along its longitudinal edge and carry it in a vertical position, avoiding a flat orientation.

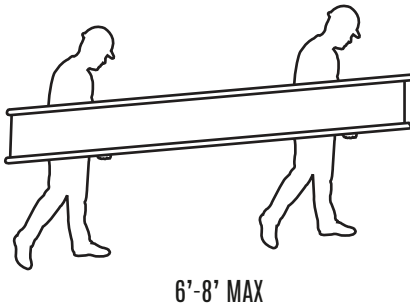

FOOT TRAFFIC

Foot traffic poses a risk of panel distortion and finish damage. It is essential to minimize traffic over the installed system. In cases where continuous foot traffic is required for maintenance, the installation of permanent walkways is recommended.

During installation, if continuous foot traffic is unavoidable, utilize walking platforms to prevent panel damage. Avoid walking directly on the ribs, as this may cause harm to the panels.

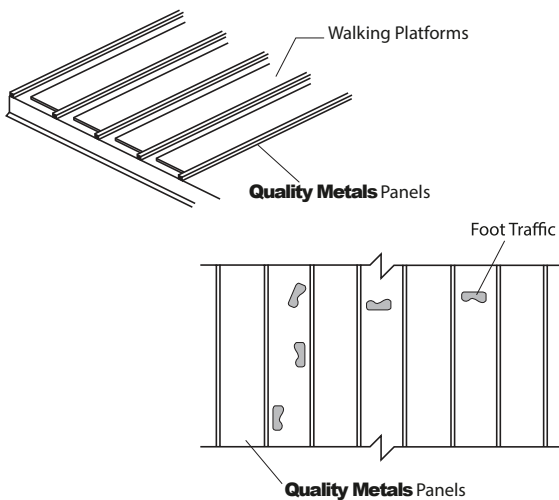

CAUTION

ALL RELEVANT SAFETY REGULATIONS, INCLUDING THOSE OUTLINED BY OSHA, MUST BE ADHERED TO THROUGHOUT THE PANEL INSTALLATION PROCESS.

FIELD CUTTING

For field cutting NS-100 panels, it is advisable to use snips or an electric tool of the "nibbler" type.

Utilizing a skill saw may result in the generation of metal chips, which can damage the finish and reduce the lifespan of the product.

To mitigate this issue, one approach is to flip the panels over during cutting, enabling the removal of metal chips from the back side of the panels.

CAUTION

ALL PRODUCT SURFACES MUST REMAIN CLEAR OF DEBRIS AT ALL TIMES. ONCE INSTALLED, SURFACES SHOULD BE WIPED CLEAN AT THE CONCLUSION OF EACH WORK PERIOD. AVOID CUTTING PANELS OVER METAL SURFACES, AS METAL SHAVINGS MAY ACCUMULATE AND LEAD TO SURFACE RUSTING, THEREBY VOIDING THE WARRANTY.

CAUTION

WHEN CUTTING METAL PANELS, IT IS IMPERATIVE TO WEAR GOGGLES FOR EYE PROTECTION.

DESIGN CONSIDERATIONS AND CALCULATIONS

Proper design and installation of vapor barriers and ventilation systems are crucial to preventing condensation and the associated problems of moisture damage and reduced insulation efficiency.

Condensation occurs when air containing moisture comes into contact with a surface whose temperature is equal to or below the dew point of the air.

This phenomenon is not exclusive to metal buildings; rather, it is a common issue in various types of construction.

In addition to providing resistance to heat transfer, insulation also serves to mitigate condensation formation on cold surfaces, whether inside the building or within the wall/roof system cavity. The arrangement of the building's insulation system and vapor retarder falls under the purview of the building designer.

Here are some fundamental guidelines to help manage condensation in metal buildings:

1. Insulation should feature a vapor retarder facing the "warm" side, typically towards the building's interior.
2. The insulation thickness must be carefully determined to maintain the vapor retarder's temperature above the interior dew point, even under extreme outside temperature conditions.
3. All perimeter conditions, seams, and penetrations of the vapor retarder must be effectively sealed to create a continuous membrane that resists the passage of water vapor.
4. Building ventilation, whether facilitated by gravity ridge vents, power-operated fans, or other means, plays a significant role in condensation reduction. Air movement towards the exterior of the building lowers the interior vapor pressure.

In buildings with an attic space or those retrofitted with a metal roof system, vents should be strategically placed at both ends of the eave and peak of the roof to prevent moisture buildup in the attic space.

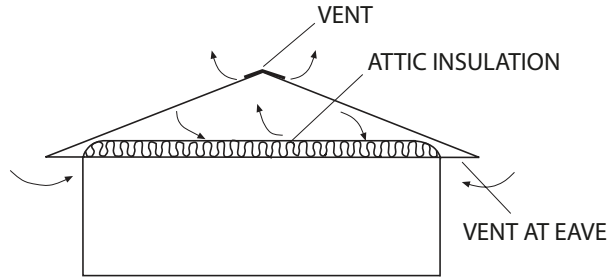

TOUCH-UP PAINT

All painted panels and flashings are equipped with a factory-applied baked-on finish. However, handling and installing panels may occasionally result in minor scratches or nicks to the paint finish.

Touch-up paint is available in matching colors for such instances. It is recommended to use a small brush for precise application of touch-up paint to areas in need of repair.



It is important to note that touch-up paint does not possess the superior chalk and fade resistance characteristic of the factory-applied paint finish. As a result, it may discolor at an accelerated rate.

Periodic touch-up painting may be necessary to maintain color consistency. However, it's essential to understand that there is no warranty on touch-up paint in terms of color matching, as the paint processes may differ.

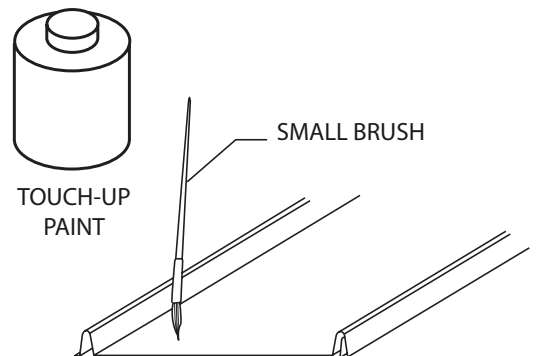
Furthermore, the use of aerosol paint is not recommended due to the potential for overspray, which may cause unintended damage.

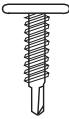
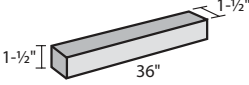
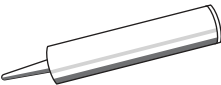

Accessories

| | | | |
|---|---|---|---|
|  |  |  |  |
| 14 X 7/8" Hex Head Lap Tek SCREW METAL TO METAL | #10 x 1 1/2" Hex Head WOODATE SCREW METAL TO WOOD | #10 x 1" Pancake Head WOOD SCREW | 2" Pancake Head WOODGRIP |
|  |  |  |  |
| 1" Pancake Head TEK SCREW | 2 1/2" Pancake Head TEK SCREW | Neoprene Universal UNIVERSAL CLOSURE | Closure |
|  |  |  |  |
| Tube Sealant | Single Bead Butyl Tape | Double Bead Butyl Tape (7/8" X 3/16" X 40') | Pipe Boot (VARIOUS SIZED, HEAT TRATED & RETRO FIT ALSO AVAILABLE) |
|  |  |  | |
| Roll Valley 20" x 50' | Hemming Tool | Flat Sheet | |

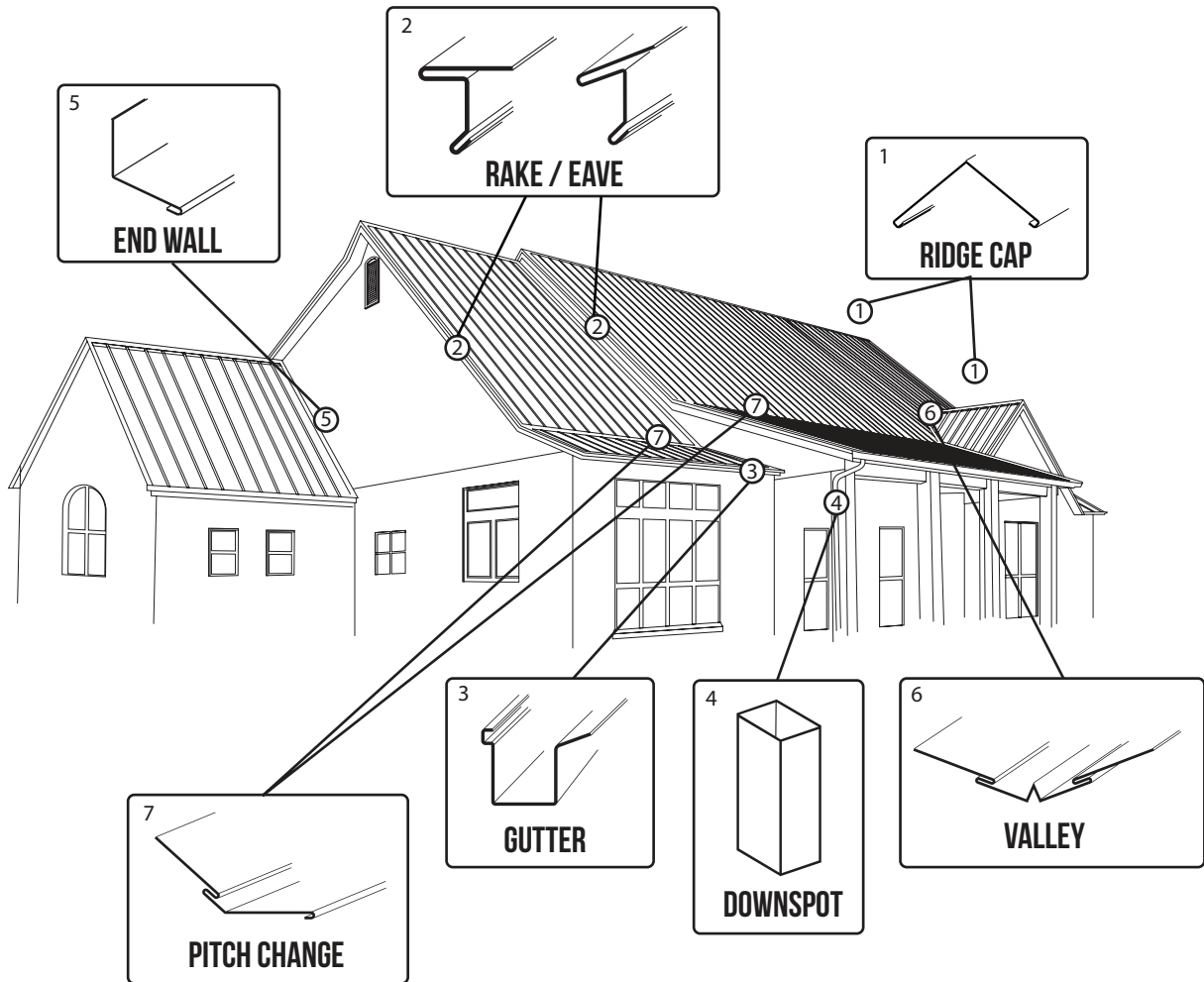

Installation

The NS-100 represents an architectural concealed fastener panel, ideally suited for roofing applications. Employing the concealed fastener method is strongly recommended due to several advantages it offers, including reduced penetrations, enhanced aesthetics at the base, and increased flexibility to accommodate thermal expansion.

Notably, for continuous runs exceeding 25 feet, adherence to the concealed fastener method becomes imperative.

1. To ensure optimal performance, QM advises the utilization of a synthetic roofing underlayment atop the roof deck or existing shingles. This underlayment serves to augment water resistance while avoiding issues such as tearing or adhesion to the metal roofing, commonly encountered with asphalt-based roofing felts.
2. During installation, aligning the female edge of the initial panel with a chalk line delineated from 0" to 1-3/4" at the rake edge is crucial. Additionally, the panel should extend over the eave by a minimum of 1 inch, as illustrated in Figure A.
3. Following hemming instructions detailed on page 09, ensure the panel is squared to the eave before securing it with 1" pancake-head wood screws, spaced at a maximum of 24 inches on center.

Note: To prevent panel distortion and allow for optimal expansion and contraction, it is imperative not to overdrive the pancake-head wood screws when affixing panels to the substrate.

Figure A

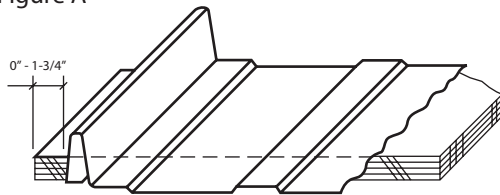
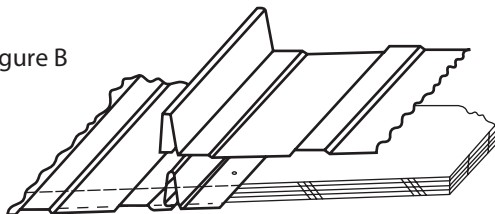

Figure B



4. Facilitating panel movement towards the eave or ridge necessitates strategic placement of the fasteners within the 5/8" slot. For expansion towards the eave, positioning the fastener at the bottom of the slot is recommended, while for securing sheets at the ridge, placing the fastener at the top of the slot is advised.
5. When aligning the second panel, ensure the female edge corresponds to the starter panel as depicted in Figure B. It is imperative that panel edges align flush with each other at the eave edge. Additionally, panels should extend over the eave by 1 inch.
6. Utilize gentle pressure with the palm of the hand to lightly compress and snap the panels together at the seam. This snapping action should proceed from the eave to the ridge.
7. Once the panel seam is securely locked and flush at the eave with the first panel, affix the panel using a 1" pancake-head wood screw along the male leg.
8. Proceed with the panel application process following steps 2 through 6 iteratively.

NAIL STRIP FASTENERS PER SQUARE

| SPACING | 16" WIDE PANEL |
|---------|----------------|
| 12" | 90 |
| 16" | 70 |
| 20" | 55 |
| 24" | 45 |

NAIL STRIP CONVERSION FACTORS

Squares to Lineal Ft.
Squares x Conversion Factor = LF

EXAMPLE

16" Wide Panel
80 x 75.15 = 6,012 LF

Field Hemming of Panel

Panel Eave and Field Hemming

When hemming panels, optimal results are achieved by cutting the ribs and performing the hemming process with the sheet inverted. For safety considerations, it is advisable to conduct panel hemming operations at ground level.

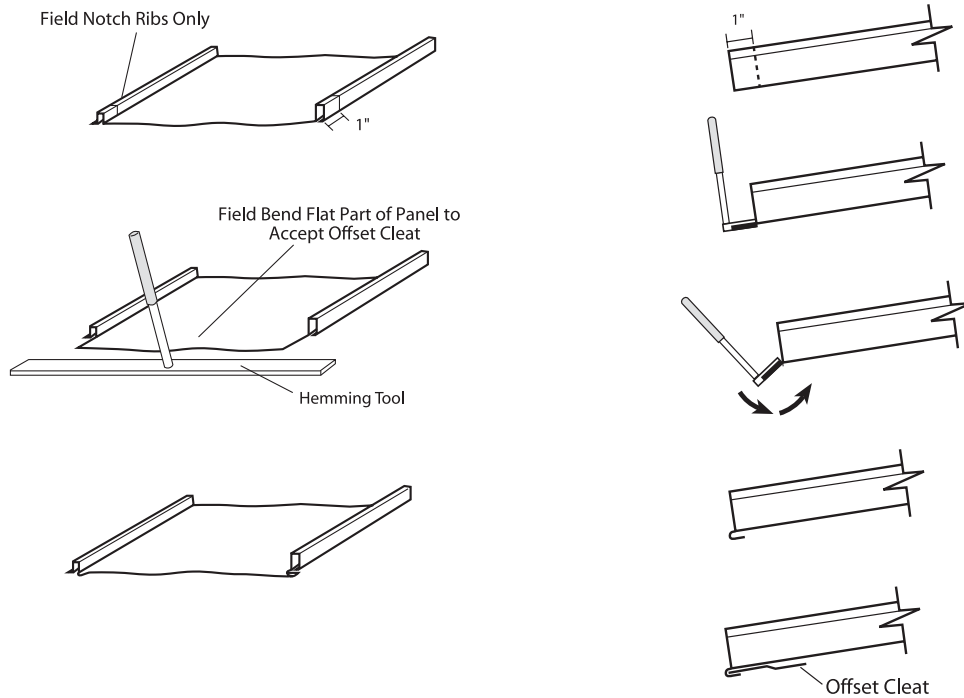

Square rake hemming detail:

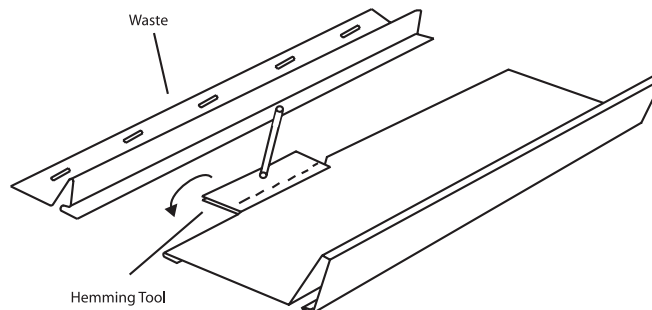

Installation

NS-100 1" NAIL STRIP OVER PLYWOOD

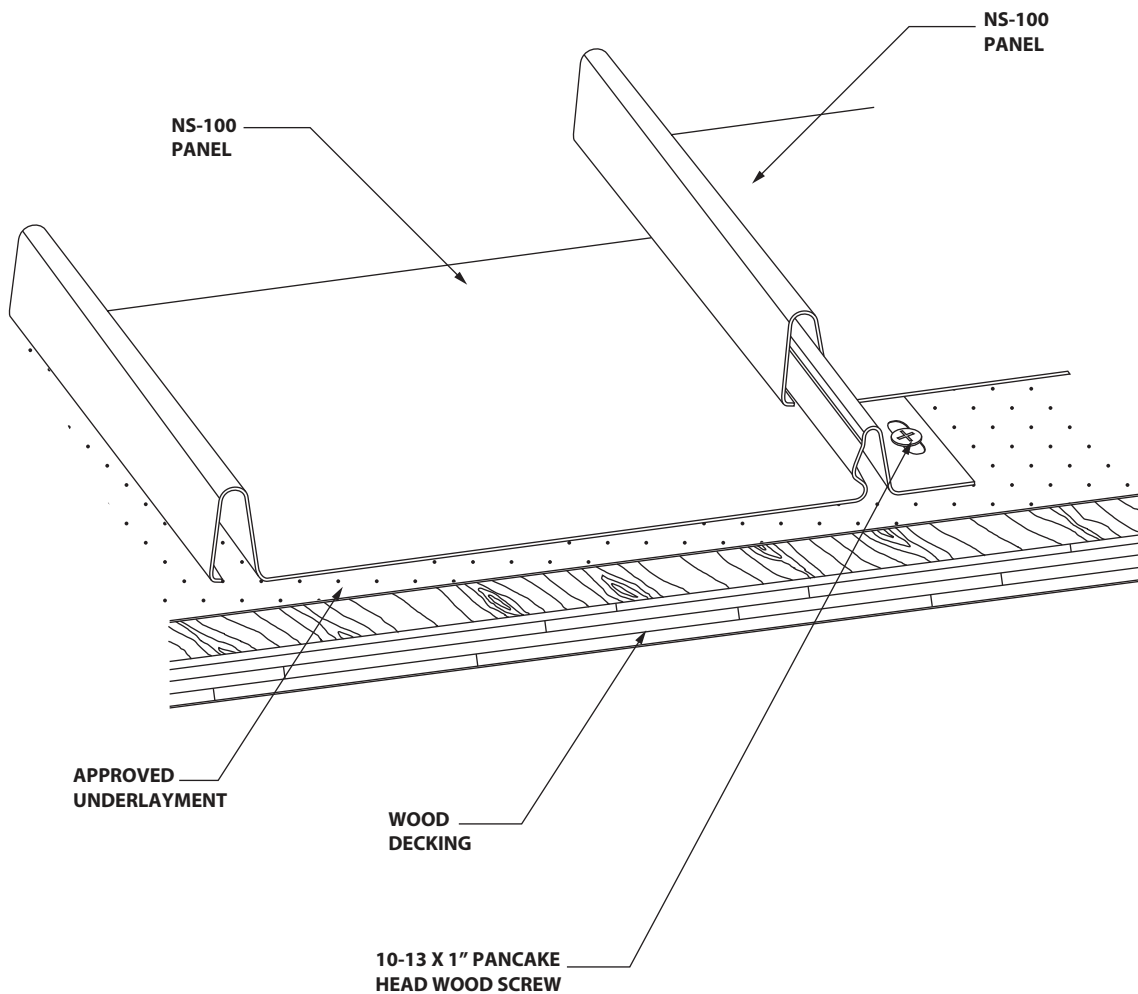

CROSS SECTION OF PANEL FASTENING

Installation

HIP AND RIDGE CAP

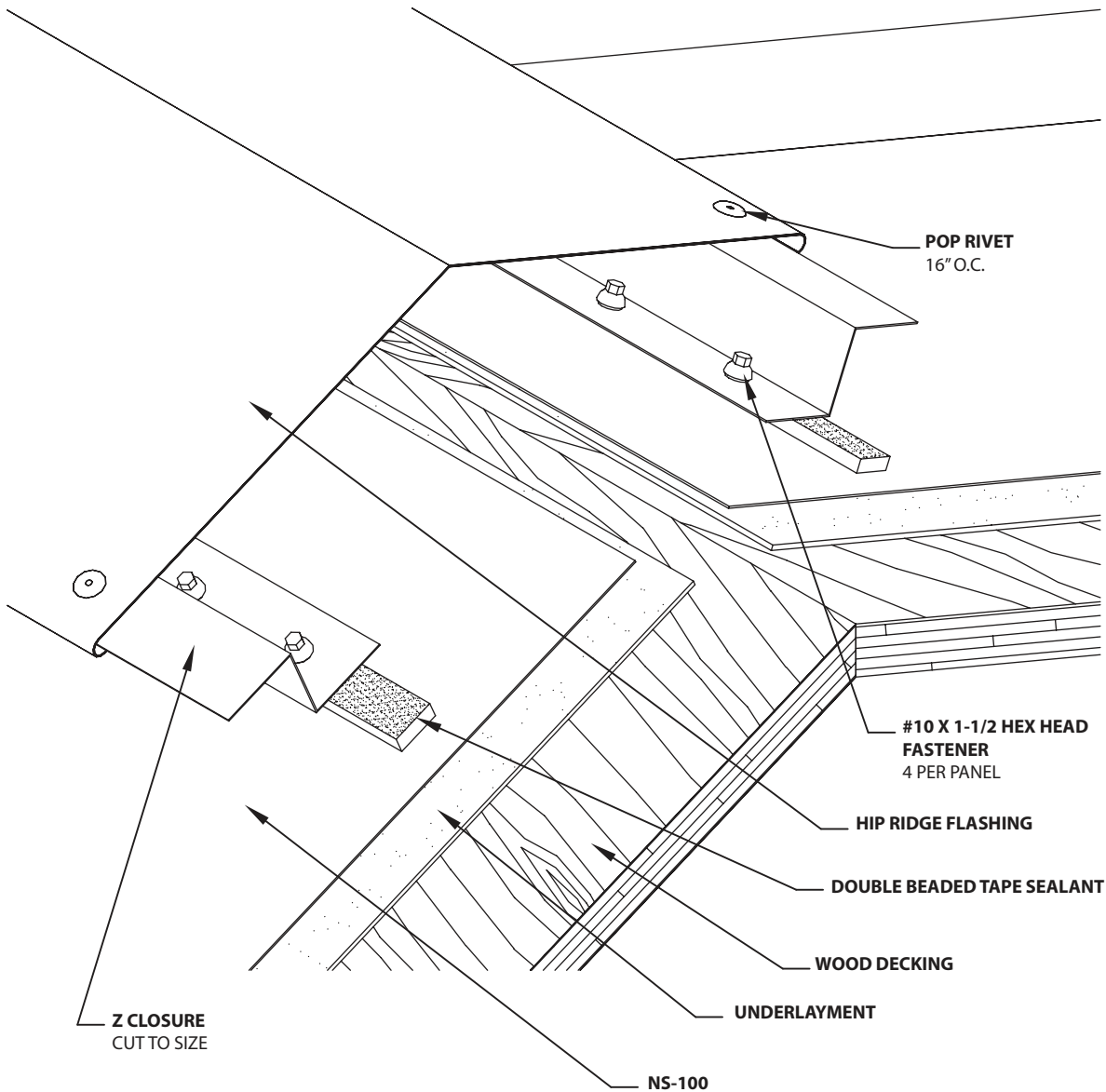

Installation

SINGLE SLOPED RIDGE

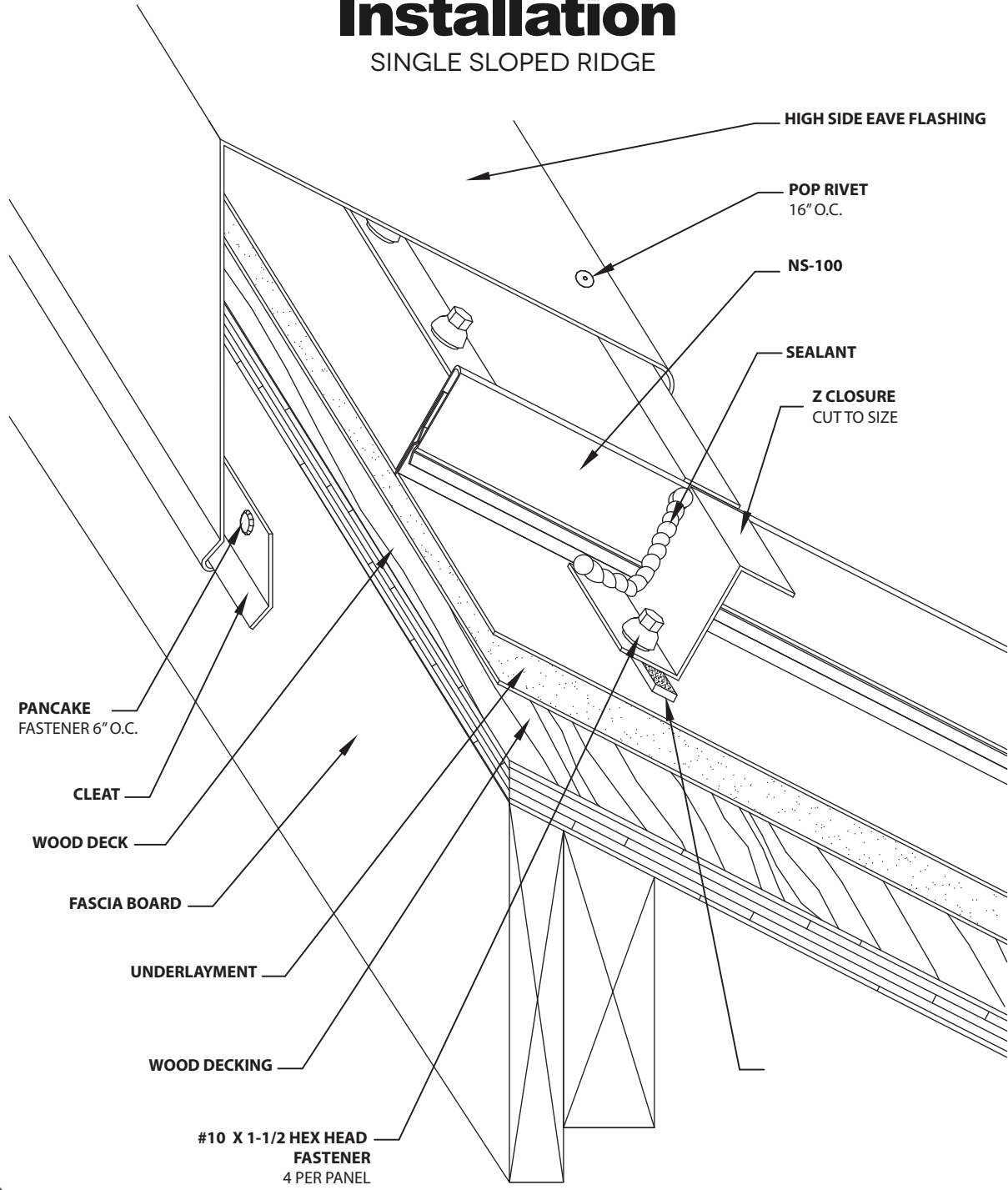

Quality Metals © ALL RIGHTS RESERVED 2023.

Installation

DRIP EDGE AT RAKE

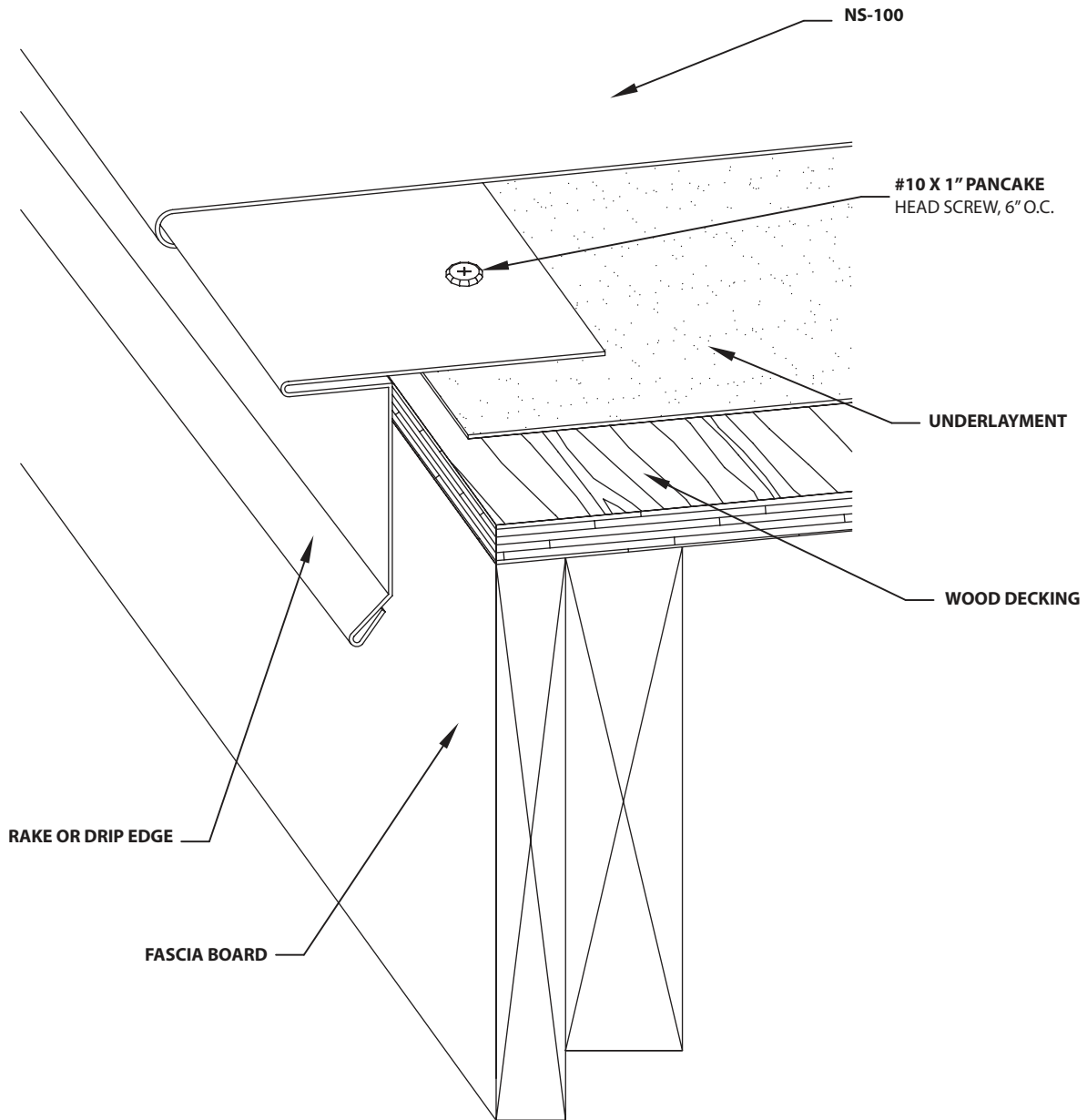

Installation

FIXED RAKE

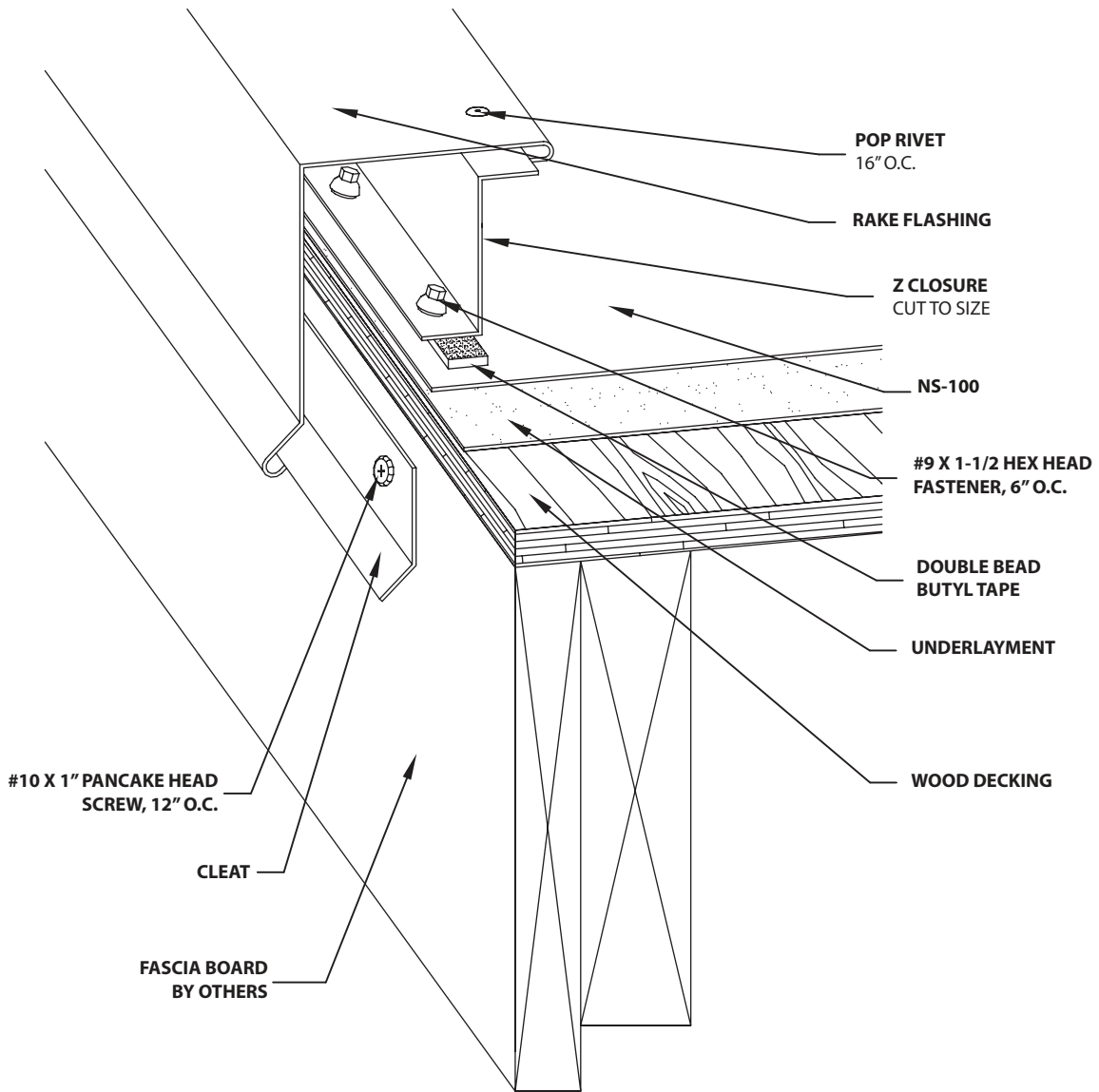

Installation

VALLEY

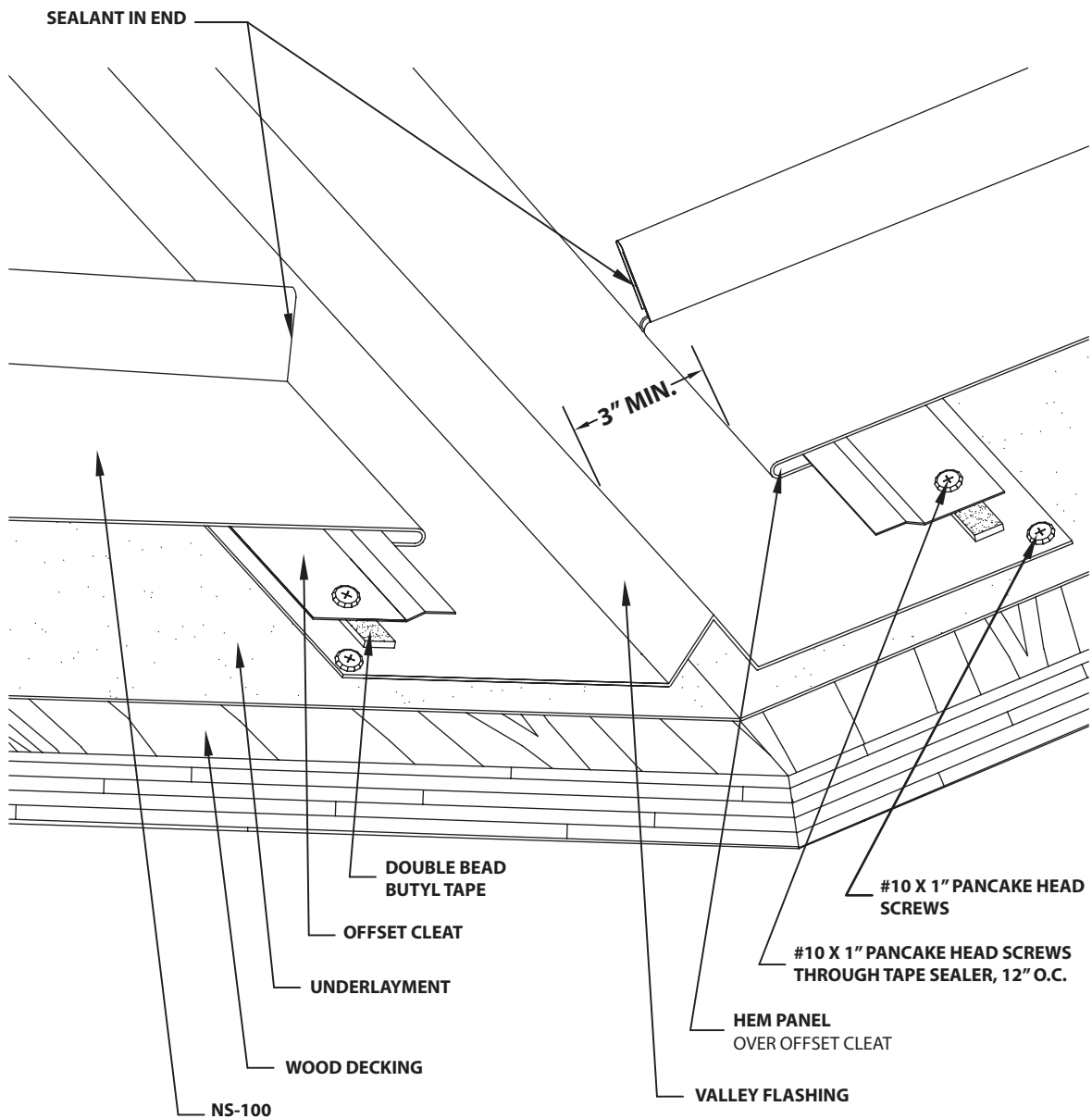

Installation

SIDE WALL

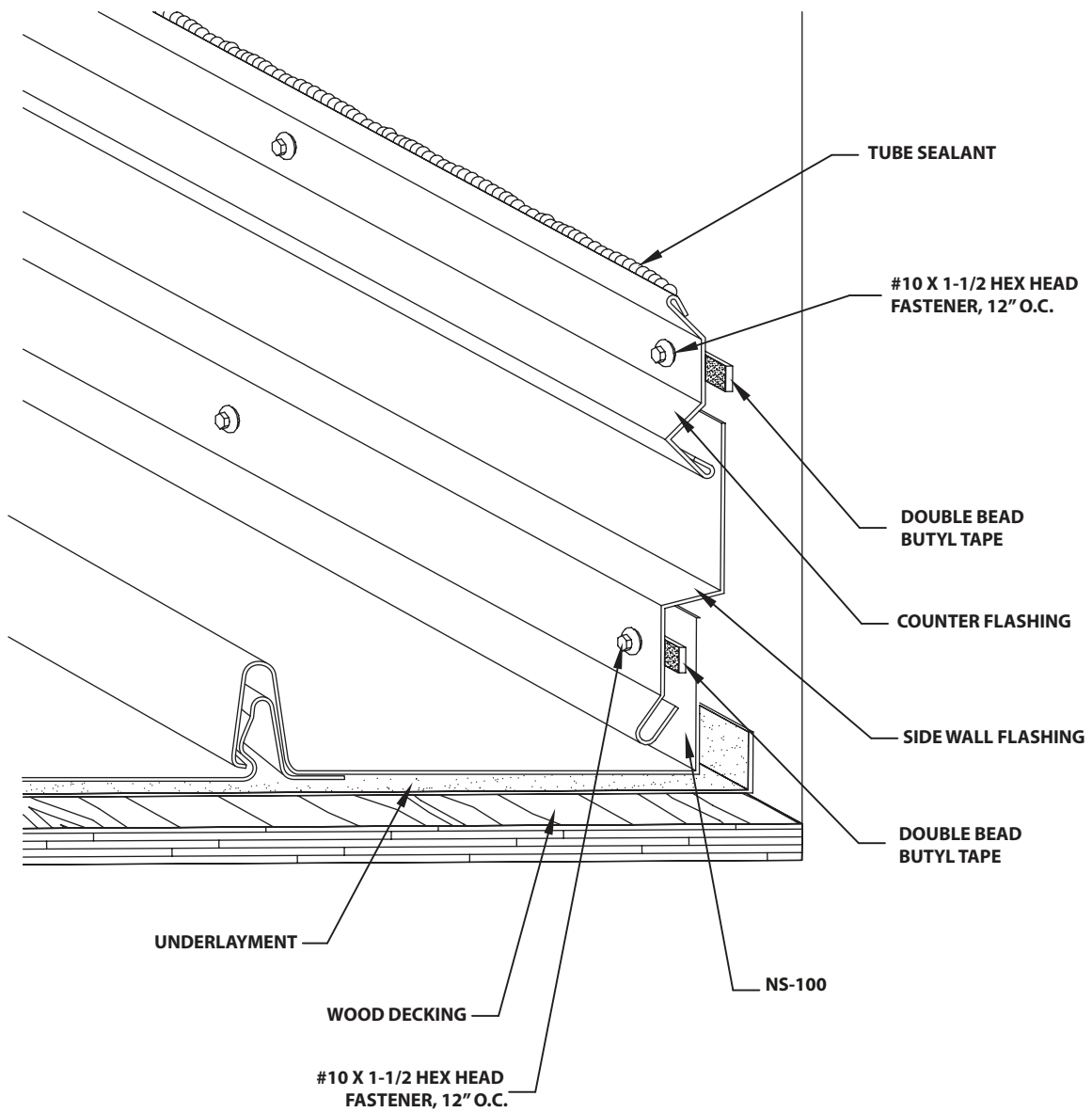

Installation

END WALL

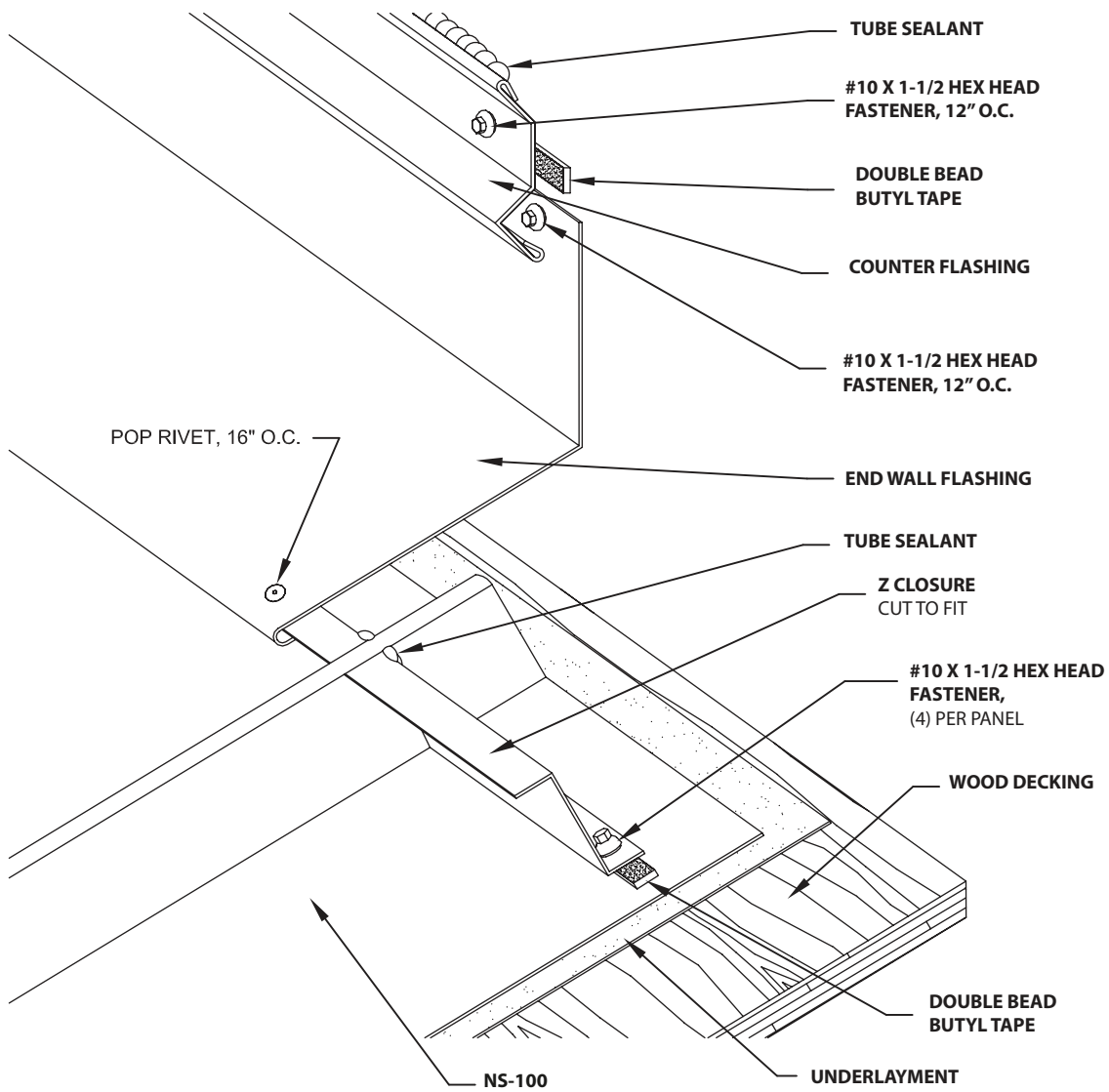

Installation

TRANSITION

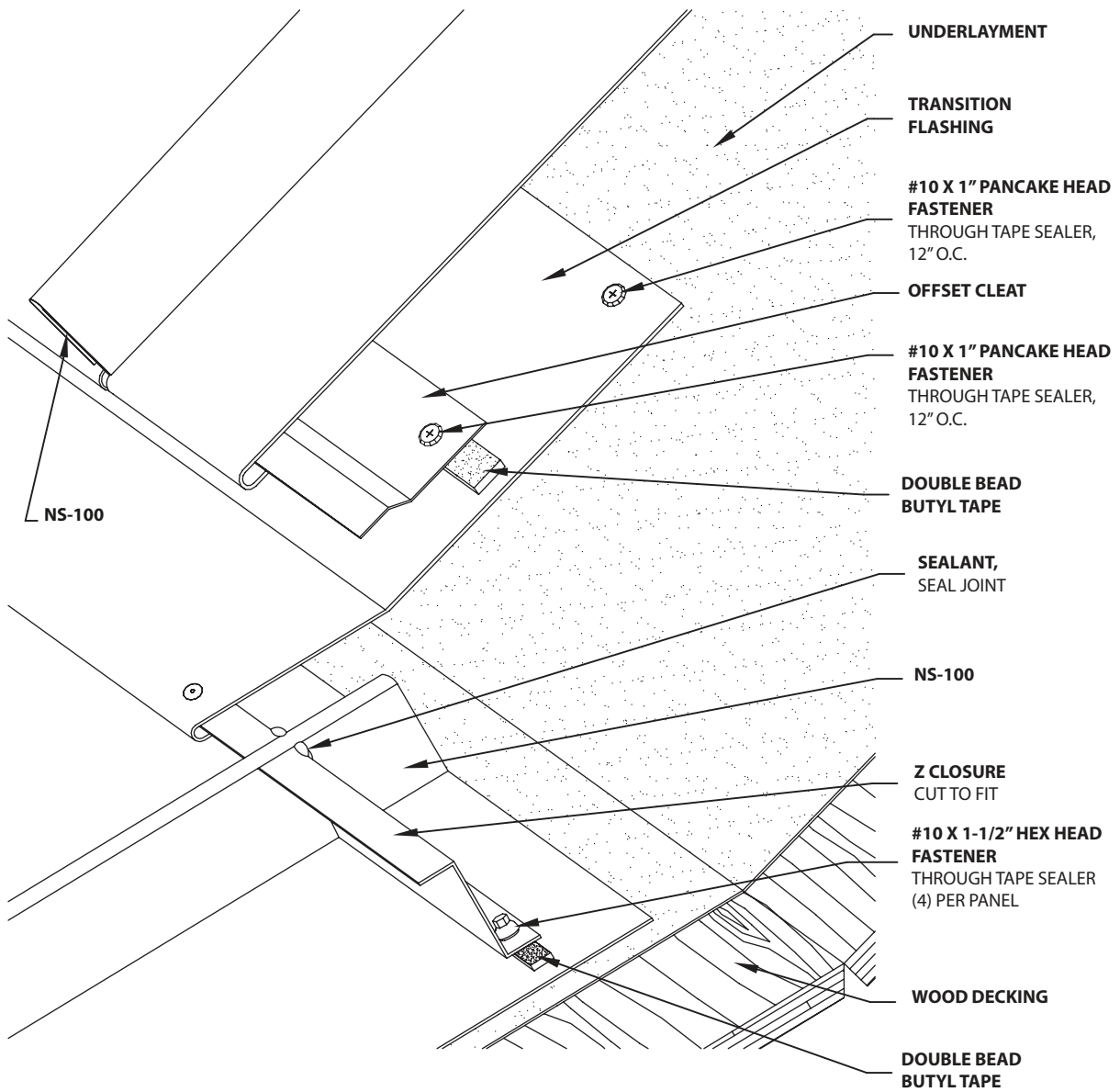

Installation

GUTTER BOX DETAIL

