



CONCEALED
FASTENER
ROOF AND WALL
SYSTEMS

Installation Manual

SLZ-150 1.5 SNAP LOCK Z

SLZ-150
SNAP LOCK Z

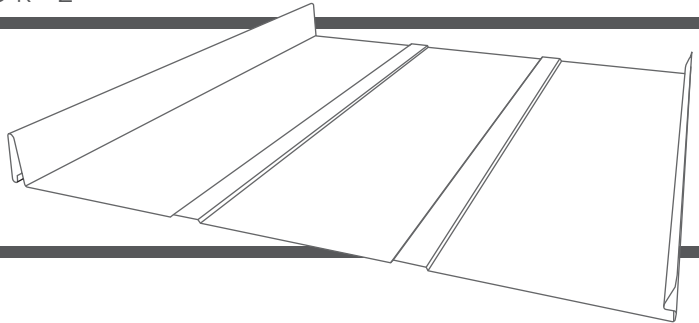

San Antonio • 2707 Castrovilla Rd • San Antonio, TX 78237 • (210) 227-727 McAllen • 2221 Austin Ave • McAllen, TX 78501 • (956) 627-2966
Dallas • 11569 Goodnight Ln • Dallas, TX 75229 • (972) 331 6800 Houston • 6460 Langfield Road • Houston, TX 77092 • (713) 944-4480

www.saqualitymetals.com

Quality Metals © ALL RIGHTS RESERVED 2023.



CONCEALED
FASTENER
ROOF AND WALL
SYSTEMS

SLZ-150
SNAP LOCK Z

IMPORTANT NOTICE

THIS MANUAL CONTAINS SUGGESTIONS AND GUIDELINES ON HOW TO INSTALL THE SUBJECT QUALITY METALS SLZ-150 AND TRIM DETAILS. THE CONTENTS OF THIS MANUAL INCLUDE THE GUIDELINES THAT WERE IN EFFECT AT THE TIME THIS PUBLICATION WAS ORIGINALLY PRINTED. IN AN EFFORT TO KEEP PACE WITH THE EVER CHANGING CODE ENVIRONMENT, QUALITY METALS RETAINS THE RIGHT TO CHANGE SPECIFICATIONS AND/OR DESIGNS AT ANY TIME WITHOUT INCURRING ANY OBLIGATIONS. TO INSURE YOU HAVE THE LATEST INFORMATION AVAILABLE, PLEASE INQUIRE OR VISIT OUR WEBSITE. APPLICATION AND DESIGN DETAILS ARE FOR ILLUSTRATIVE PURPOSES ONLY AND MAY NOT BE APPROPRIATE FOR ALL ENVIRONMENTAL CONDITIONS AND/OR BUILDING DESIGNS. PROJECTS SHOULD BE ENGINEERED AND INSTALLED TO CONFORM TO APPLICABLE BUILDING CODES, REGULATIONS AND ACCEPTED INDUSTRY PRACTICES.

READ THIS MANUAL COMPLETELY PRIOR TO BEGINNING THE INSTALLATION OF QUALITY METALS SLZ-150 ROOFING SYSTEM.

ALWAYS INSPECT EACH AND EVERY PANEL AND ALL ACCESSORIES BEFORE INSTALLATION, NEVER INSTALL ANY QUALITY METALS PRODUCT IF ITS DAMAGE, NOTIFY QUALITY METALS IMMEDIATELY IF ANY PRODUCT IS NOT ACCORDING TO SPECIFICATION OR HAS BEEN DAMAGE.



CONCEALED
FASTENER
ROOF AND WALL
SYSTEMS

Quality Metals © ALL RIGHTS RESERVED 2023.

INTRODUCTION

SLZ-150 Concealed System is an architectural (non-structural) panel which is snapped together during installation. The product is an integral interlocking system by design meaning the panels install in one direction from a given starting point.

SLZ-150 panel gives you the leak resistance and beauty of traditional standing seam roof without the expense and difficulty of seam, The Clips combined with the snap system allow the panel to easily expand and contract with the temperature changes.



APPLICATIONS

Low-profile Concealed Fastening Roof System. Ideal for residential and light commercial applications.

Low system for easy installation.

Symmetrical visual aesthetics: providing a non-directional appearance.

SPECIFICATIONS

Color and Finishes

- 24 and 26 Gauge Galvalume[®]
- 35 Year warranty on Durapont 70 finish.

WIDTHS

- Actual Panel Coverage (Width): 12" to 24"
- Minimum Slope = 3½":12"

LENGTHS

SLZ-150 Panels is available in standard lengths from 4' to 40'. Longer lengths require additional handling, packaging and shipping considerations. An extra handling charge may apply to panels over 40'.

Continuous Roll-formed lengths: eliminates need for panel lap joints.

DESIGN

Completely Concealed Fastener Roofing. SLZ-150 requires low maintenance and easy installation. Whether you have a new construction or re-roofing project. SLZ-150 will work on either.

TESTING

- UL-790 Fire Test of Roof Coverings, Class A,B, C.
- UL-2218 For impact Resistance Class4.
- UL 580 Uplift Resistance Class 90.

INSTALLATION

- Solid Substrate Required
- Snap Seam- No field Seaming Required
- Weathertight Warranty is not available.
- Underlayment Required.

OIL CANNING

Offset, striations and pencil ribs provide strength and reduce the incidence of oil canning.

TOOLS AND EQUIPMENT

Installer must have prior experience and knowledge of the tools listed below and their uses working with metal roofing.

- Caulking Gun
- Snips
- Cordless Screw Gun
- Pop Rivet Tool
- Tape Measure
- Hemming Tool
- Electrical Extension Cord
- Heavy Gloves
- Safety Glasses.

MECHANICAL HANDLING

FORKLIFT

A forklift may be used for panels up to 20' long. Please make sure the forks are at their maximum separation. Do not transport open crates. When transporting crates across rough terrain, or for a long distance, some means of supporting the panel load must be used.

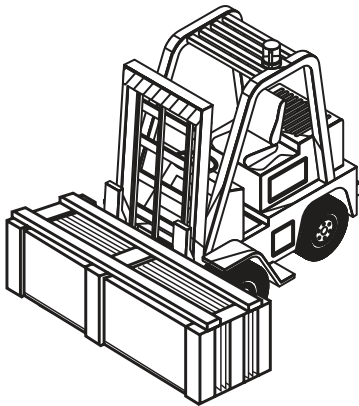

CRANE

A crane should be used when lifting panels with lengths greater than 20'. Please be sure to utilize a spreader bar to ensure the even distribution of the weight to the pick up points. As a rule, when lifting panels, no more than 1/3 of the panel length should be left unsupported. Canvas or nylon sling should be used to pick up the panels. **DO NOT USE CABLE OR CHAINS** because this will damage the panels.

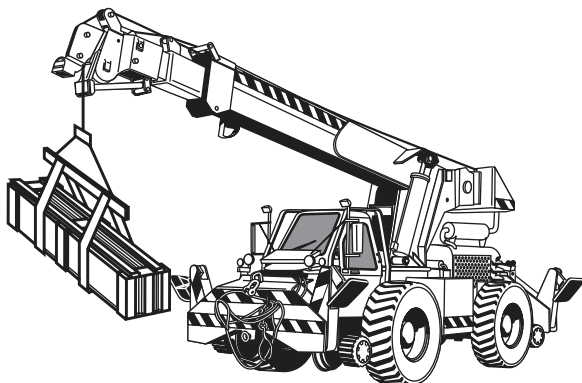

CAUTION

IMPROPER LOADING AND UNLOADING OF CRATES MAY RESULT IN BODILY HARM AND/OR MATERIAL DAMAGE. QUALITY METALS IS NOT RESPONSIBLE FOR BODILY INJURIES AND/OR MATERIAL DAMAGES RESULTING FROM IMPROPER LOADING AND UNLOADING.

GENERAL HANDLING

Each crate should be handled carefully to avoid being damaged. Care should be taken to prevent bending of the panel or abrasion to finish. Please follow these steps for proper care while unloading and handling crates in order to prevent panel damage:

1. Crates should remain intact during any handling, and until the individual panels in each bundle are ready to be installed. Crates should never be lifted by the banding.
2. Lift each crate as close as possible to its center of gravity.
3. If the crates are to be lifted with a crane, use a spreader bar of appropriate length, and nylon band slings. (do not use wire rope slings as they will damage the panels).
4. Depending on panel length, some crates may be lifted by a forklift, the forks should be spread apart to their maximum spacing, and the load must be centered on the forks to prevent scratching the next panel. A panel should never be picked up by its ends. Instead, lift the panel along its longitudinal edge and carry in a vertical (not flat) position. For panels over 10 feet long, two or more people should lift the panel along the same edge.
5. After crates are opened, individual panels must also be handled carefully to prevent panel buckling or damage to the panel coating. When removing a panel from a crate, it should be never be allowed to slide over another panel. The individual panels should be "rolled" out of the crate in order to minimize the chance of panel damage.

MANUAL HANDLING

6. Soft gloves must be worn when handling panels.

A panel should be never be picked up by its ends. Instead, lift the panel along its longitudinal edge and carry in a vertical (not flat) position.

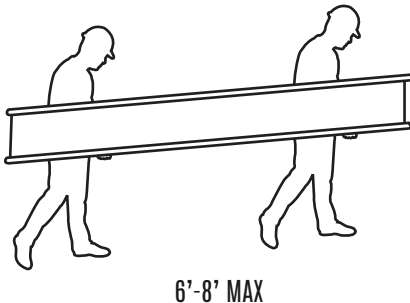

FOOT TRAFFIC

Foot traffic can cause distortion of panel and damage to finish. Traffic over the installed system must be kept to an absolute minimum. If continuous foot traffic is necessary for maintenance over certain areas of the roof, then a permanent walkaway should be installed.

If continuous foot traffic is necessary during installation, provide walking platforms to avoid any panel damage as shown below. Walking on the ribs can cause damage of the panels.

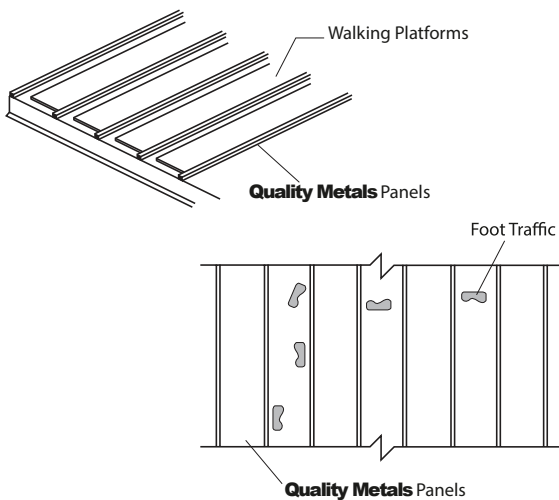

CAUTION

ALL APPLICABLE SAFETY REGULATIONS, INCLUDING OSHA REGULATIONS, MUST BE COMPLIED DURING PANEL INSTALLATION PROCESS.

FIELD CUTTING

The snips or a "nibbler" type electric tool are recommended for field cutting SLZ-150 panels. If a skill saw is used, the blade will generate slivers of metal chips. Any slivers of metal chips must be immediately removed from the SLZ-150 panels because they will damage the finish and shorten the life of the product.

One method of preventing this problem is to flip the panels over when cutting. This allows the slivers of metal chips to be brushed from the back side of the panels.

CAUTION

ALL PRODUCT SURFACES SHOULD BE FREE OF DEBRIS AT ALL TIMES. INSTALLED SURFACES SHOULD BE WIPED CLEAN AT THE END OF EACH WORK PERIOD. NEVER CUT PANELS OVER METAL SURFACES. METAL SHAVINGS WILL RUST ON THE SURFACE THUS VOIDING THE WARRANTY.

CAUTION

WHEN CUTTING METAL PANELS, GOGGLES MUST BE WORN FOR EYE PROTECTION.

DESIGN CONSIDERATIONS AND CALCULATIONS

Proper design and installation of vapor barriers and ventilation systems are important to prevent condensation and resulting problems of moisture damage and loss of insulation efficiency.

Condensation occurs when moisture-laden air comes in contact with a surface temperature equal to or below the dew point of the air. This phenomenon creates problems that are not unique with metal buildings; these problems are common to all types of construction.

In addition to providing resistance to heat transfer, insulation can also protect against condensation forming on cold surfaces, either inside the building or within the wall/roof system cavity. The arrangement of the building's insulation system and vapor retarder is the responsibility of the building designer. These are some basic guidelines to help control condensation in a metal building.

1. The insulation should have a vapor retarder face on the "warm" side of the insulation. For most buildings, this means that the vapor retarder is on the side surface. (toward the building's interior)
2. The thickness of the insulation must be designed to maintain the temperature of the vapor retarder above the interior dew point, using the worst-case expected outside temperature.
3. All perimeter conditions, seams, and penetrations of the vapor retarder must be adequately sealed in order to provide a continuous membrane to resist the passage of water vapor.
4. Building ventilation, whether by gravity ridge vent, power operated fans, or other means, contributes significantly to reduce condensation. The movement of air to the outside of the building reduces the interior level of vapor pressure.

On buildings that have an attic space or are being retrofitted with a metal roofing system, vents should be placed at both ends of the eave and peak of the roof in order to prevent a buildup of moisture (humidity) in the attic space.

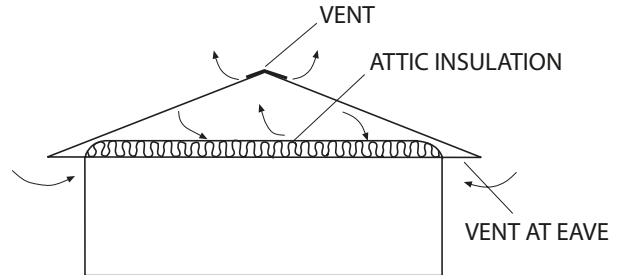



TOUCH-UP PAINT

All painted panels and flashings have a factory applied baked on finish. Handling and installing panels may result in some small scratches or nicks to the paint finish.

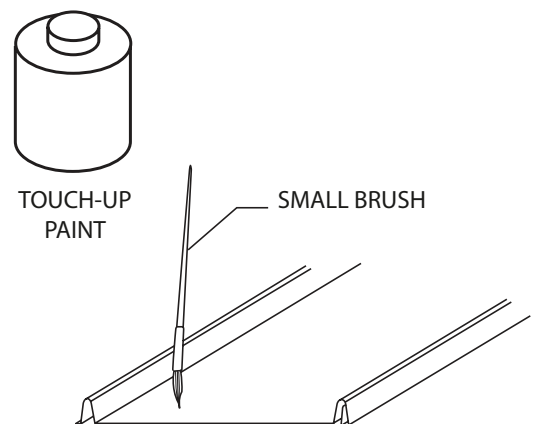
Touch-up paint is available in matching colors. It is recommended that a small brush be used to apply touch-up paint to those areas that are in need of repair. Touch-up paint does not have the superior chalk and fade resistance of the factory applied paint finish and will normally discolor at an accelerated rate. Periodic touch-up paint may be required to maintain color match. There is no warranty on touch-up paint in regards to color match because the paint processes are different. Aerosol paint should not be used because the overspray that may occur.

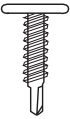
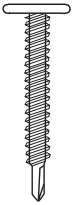
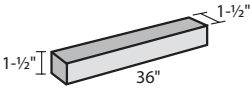
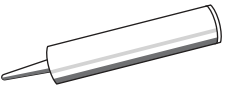
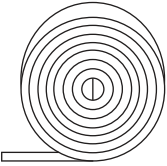
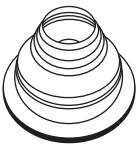
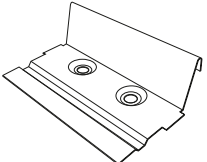
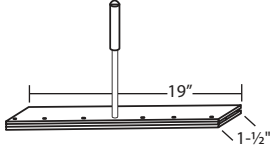

Accessories

			
14 X 7/8" Hex Head Lap Tek SCREW METAL TO METAL	#10 x 1 1/2" Hex Head WOODATE SCREW METAL TO WOOD	#10 x 1" Pancake Head WOOD SCREW	2" Pancake Head WOODGRIP
			
1" Pancake Head TEK SCREW	2 1/2" Pancake Head TEK SCREW	Neoprene Universal UNIVERSAL CLOSURE	Closure
			
Tube Sealant	Single Bead Butyl Tape	Double Bead Butyl Tape (7/8" X 3/16" X 40')	Pipe Boot (VARIOUS SIZED, HEAT TRATED & RETRO FIT ALSO AVAILABLE)
			
Clip	Roll Valley 20" x 50'	Hemming Tool	Flat Sheet

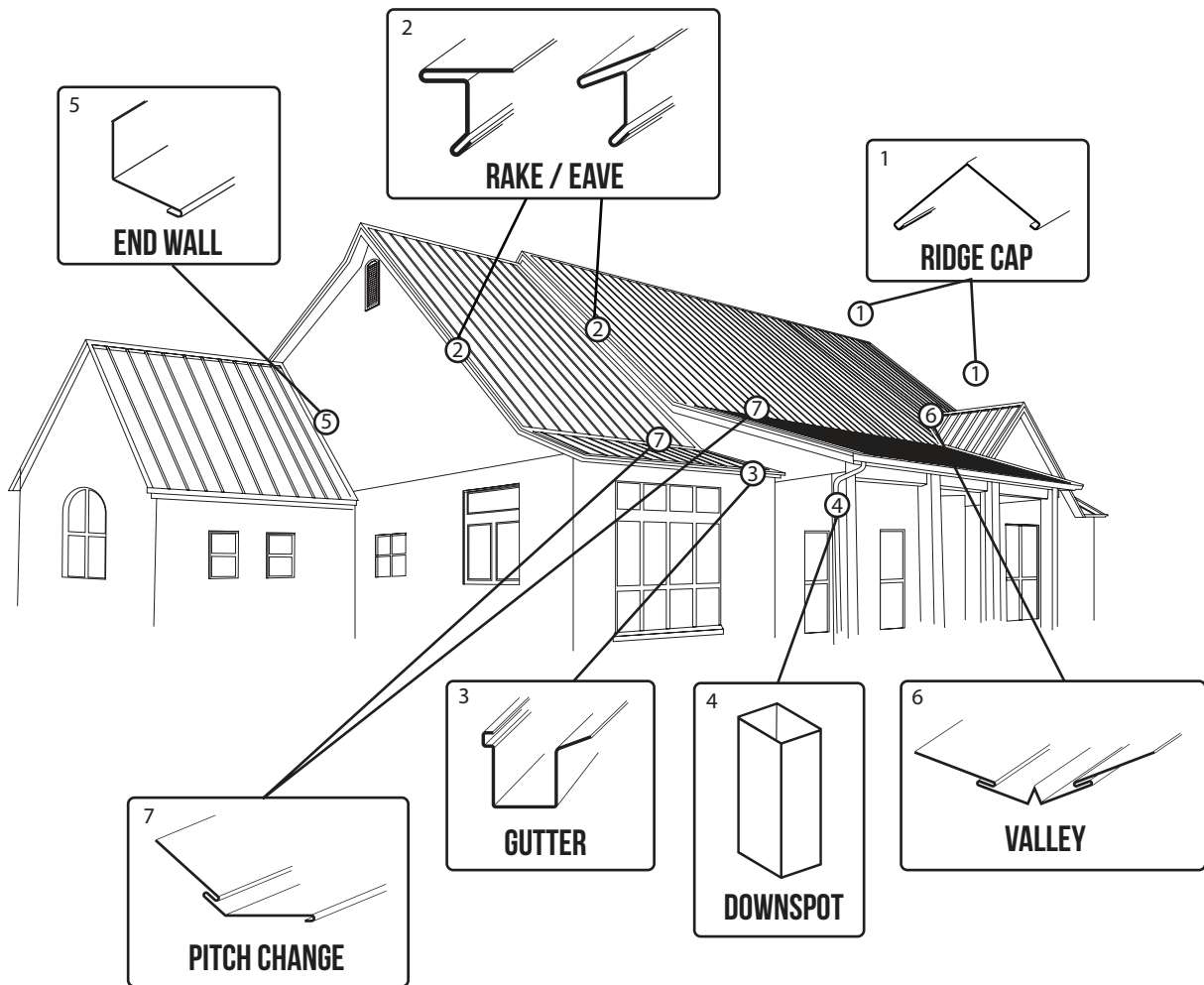

Installation

CROSS SECTION OF PANEL FASTENING

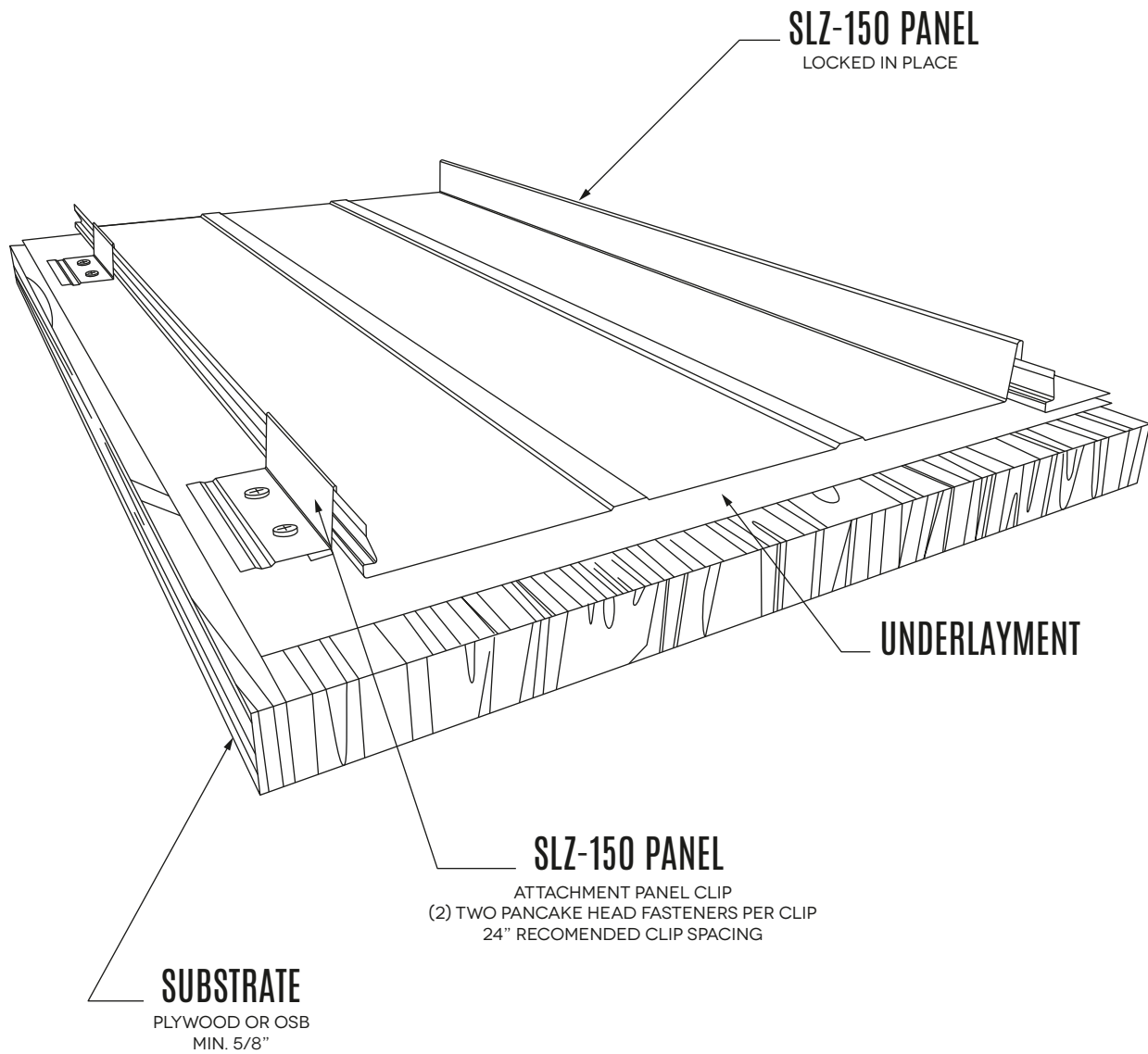

Installation

HIP AND RIDGE CAP

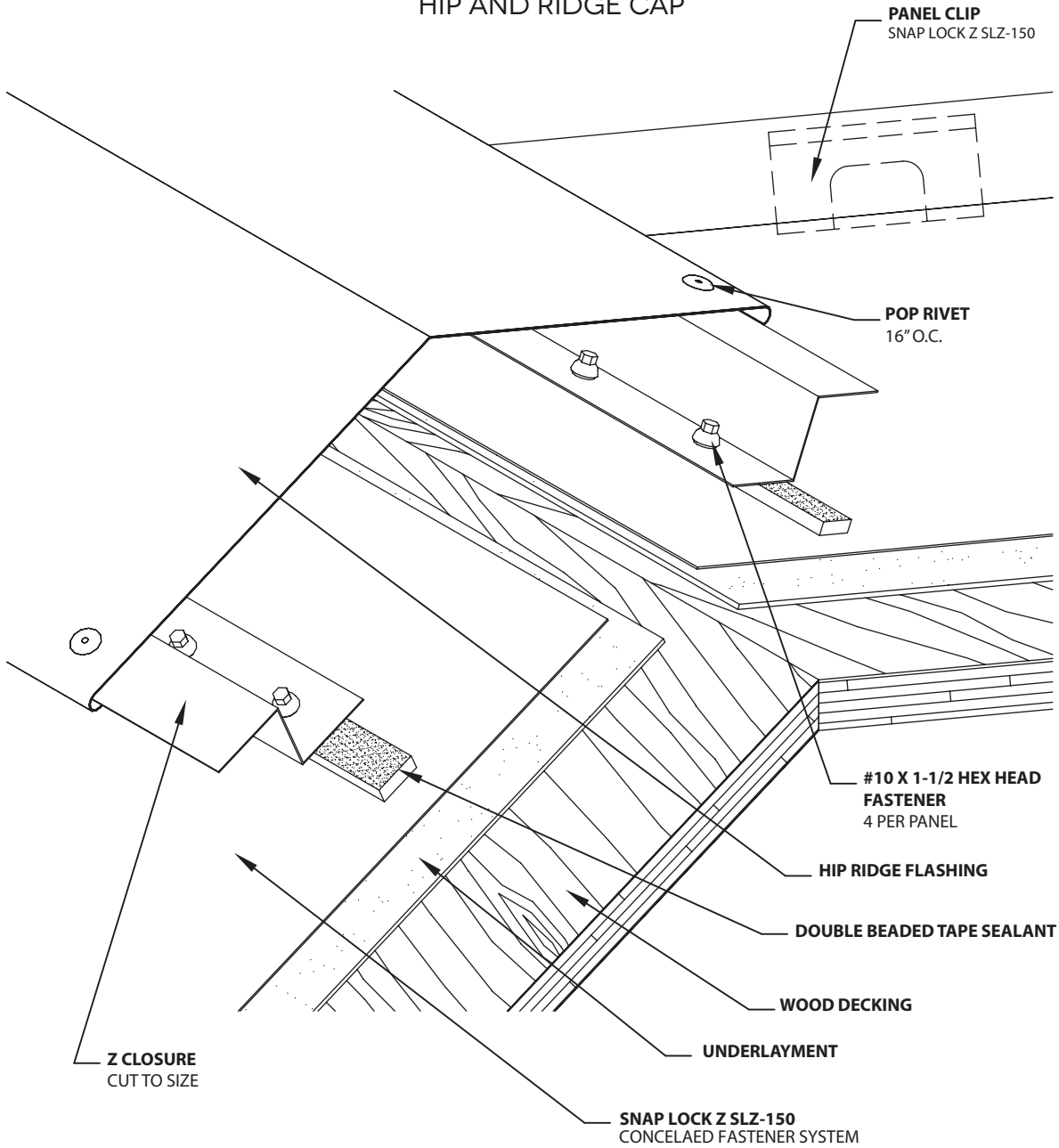

Quality Metals © ALL RIGHTS RESERVED 2023.

Installation

SINGLE SLOPED RIDGE

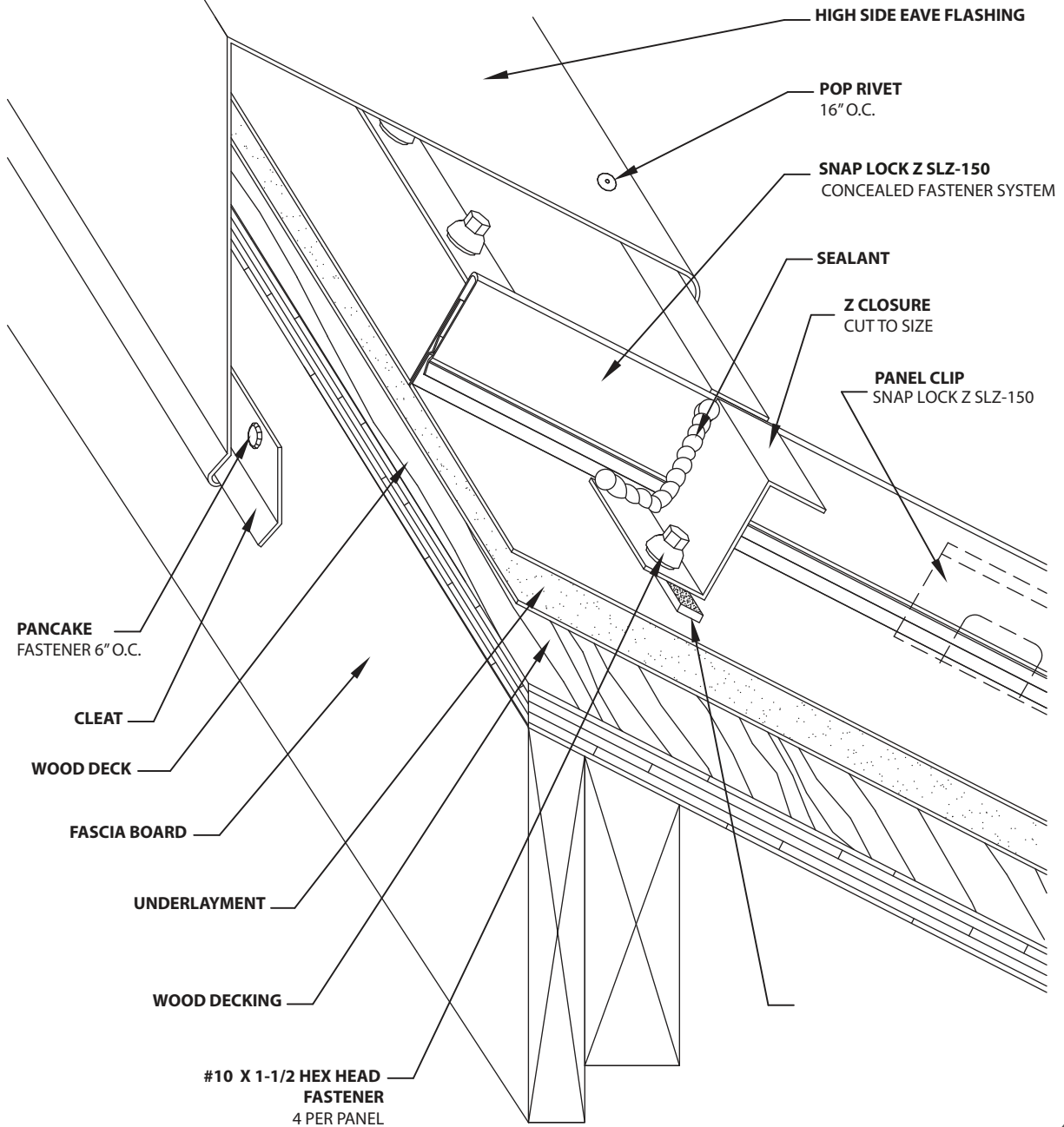

Installation

DRIP EDGE AT RAKE

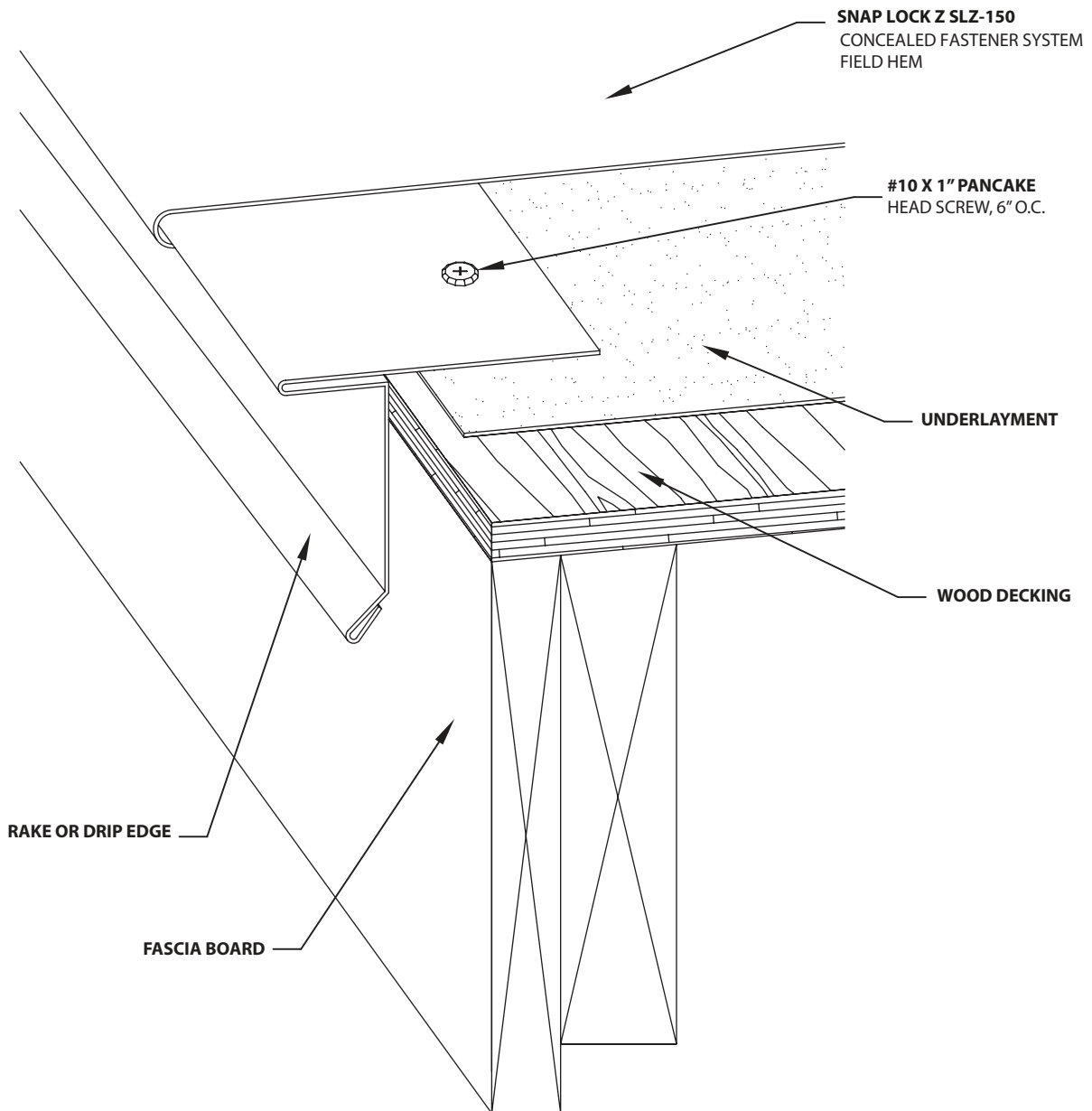

Installation

BOX RAKE

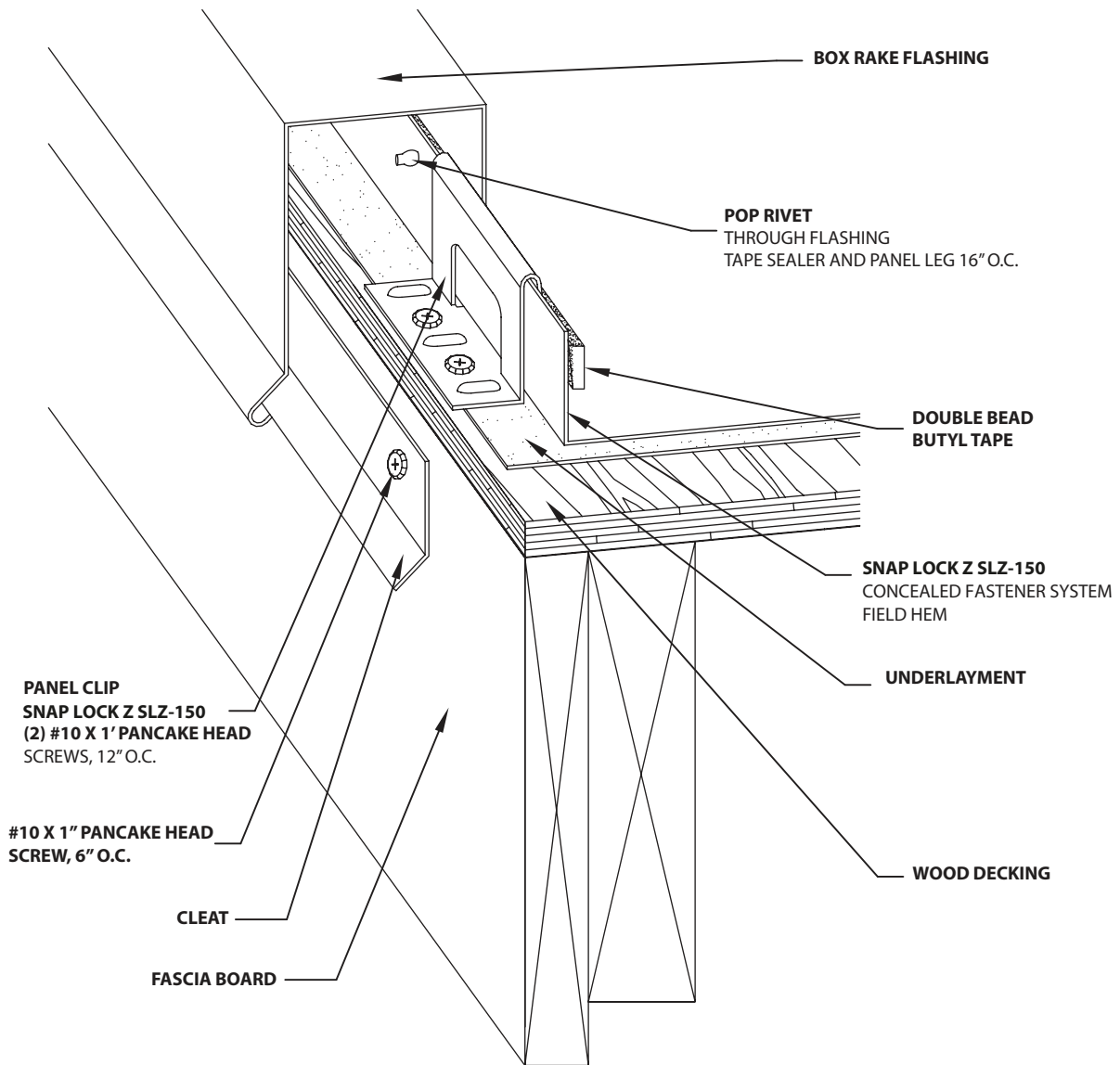

Installation

FIXED RAKE

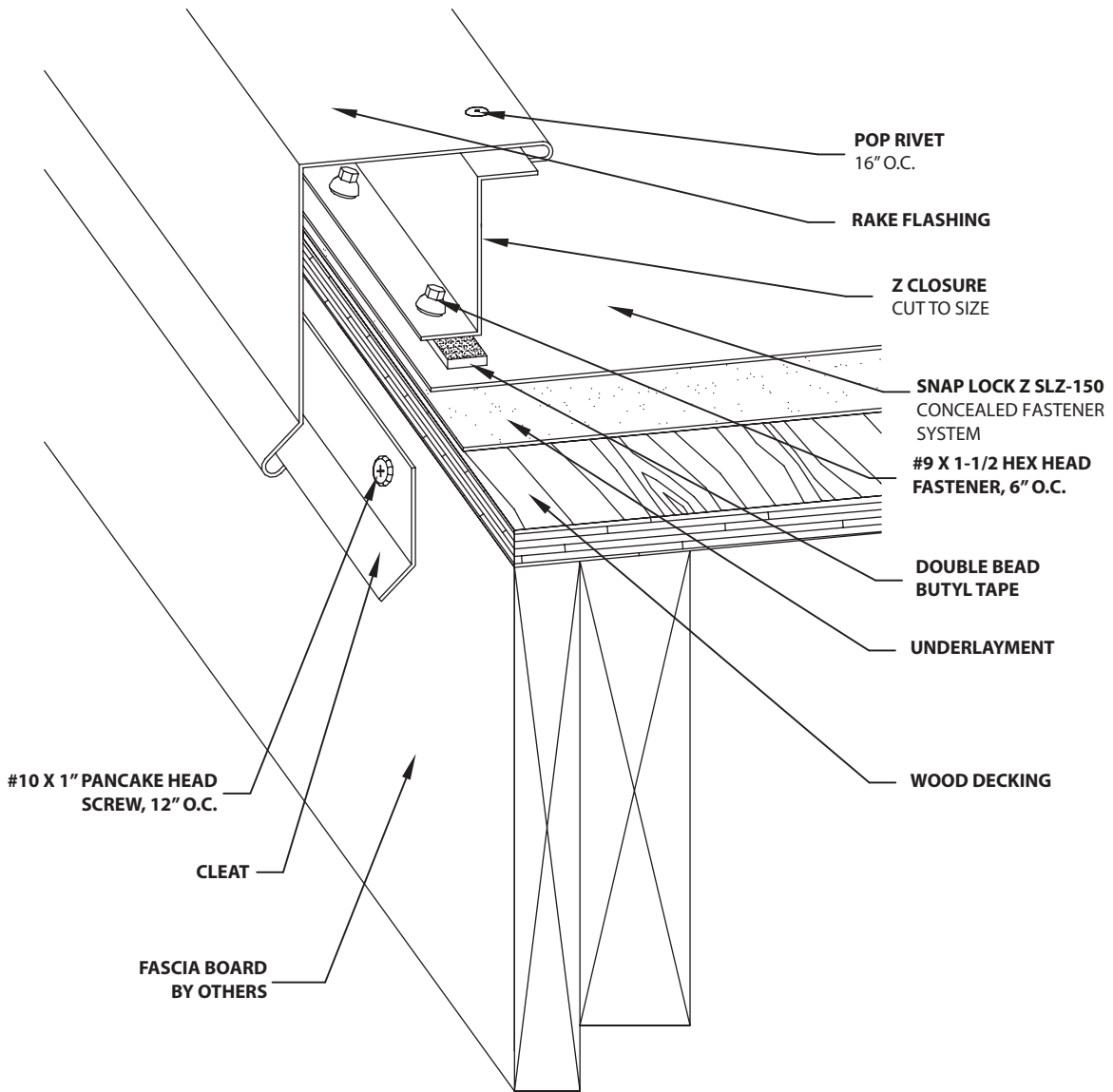

Installation

VALLEY

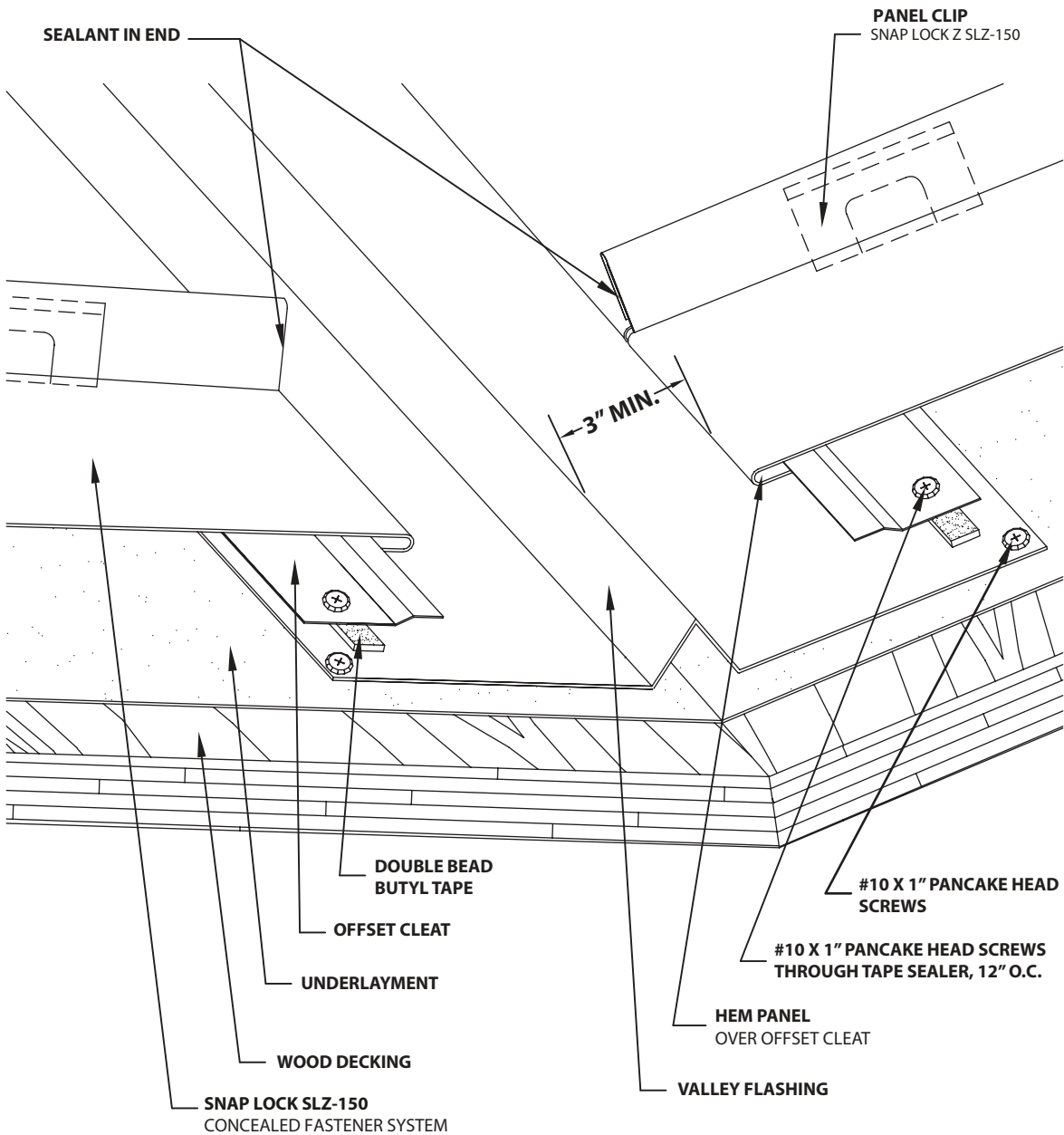

Installation

SIDE WALL

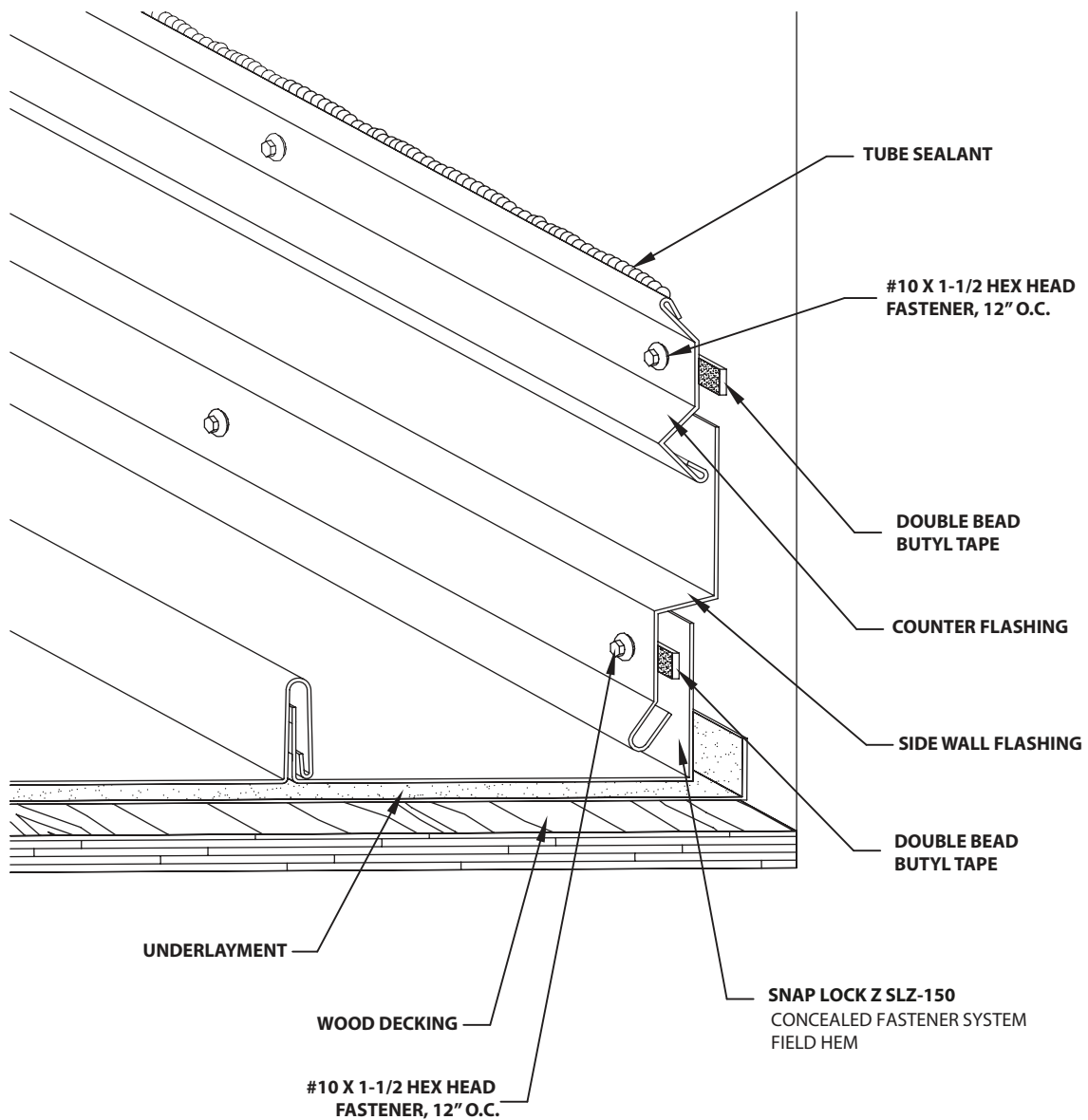

Quality Metals © ALL RIGHTS RESERVED 2023.

Installation

END WALL

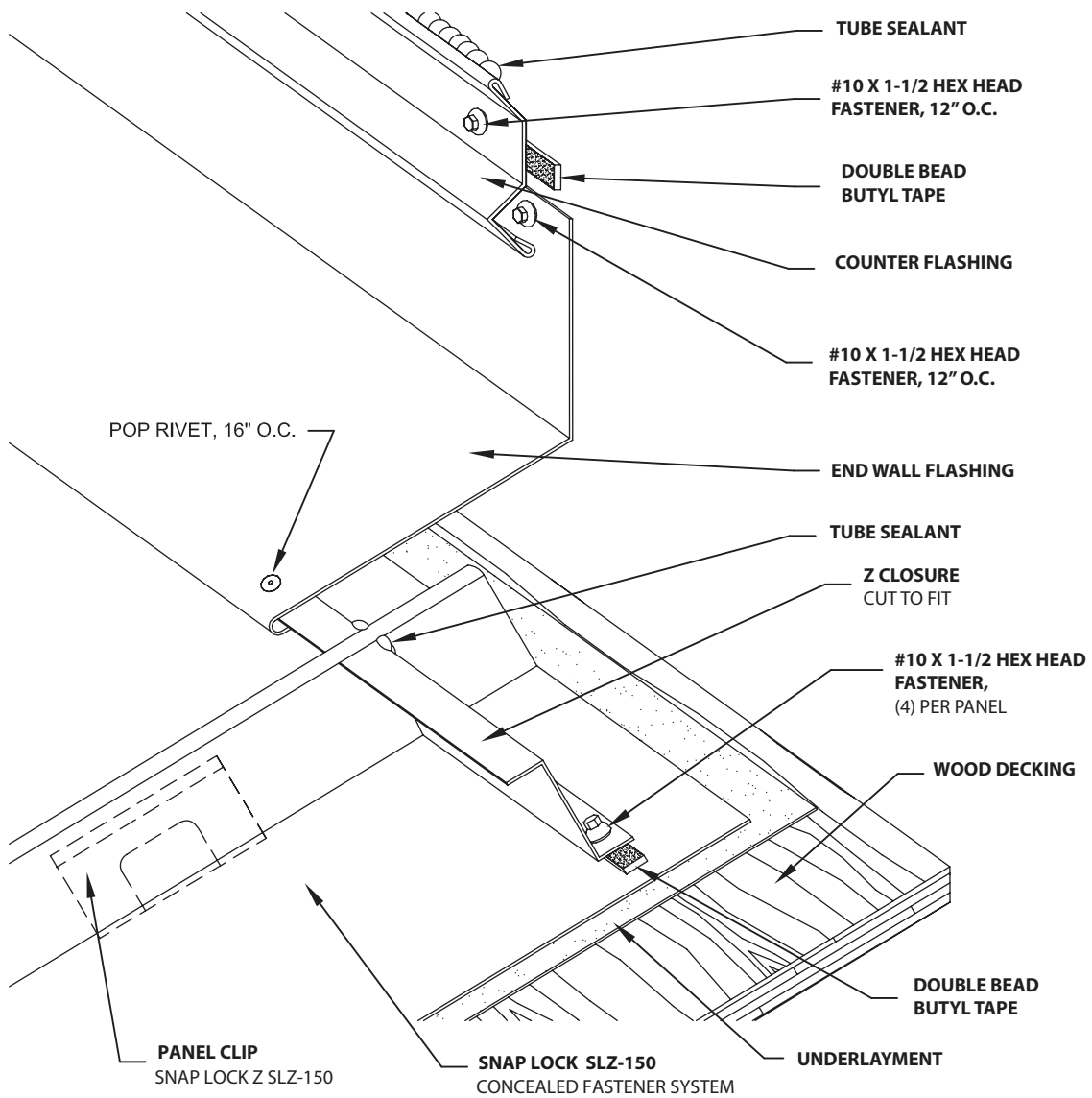

Quality Metals © ALL RIGHTS RESERVED 2023.

Installation

TRANSITION

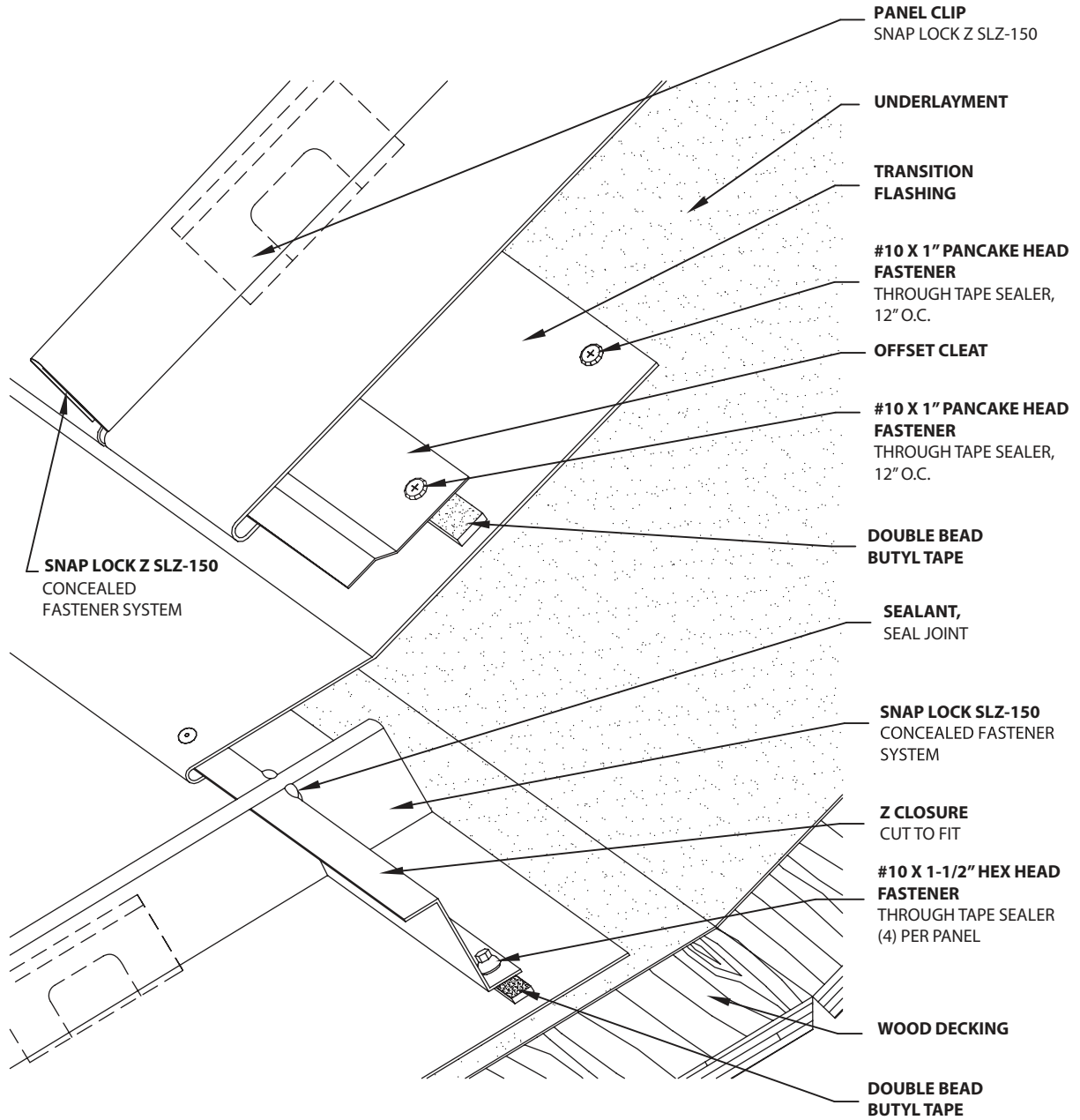

Quality Metals © ALL RIGHTS RESERVED 2023.

Installation

GUTTER BOX DETAIL

