



STANDING SEAM ROOF SYSTEMS

Installation Manual

ML-15Q

1.5 MECHANICAL LOCK

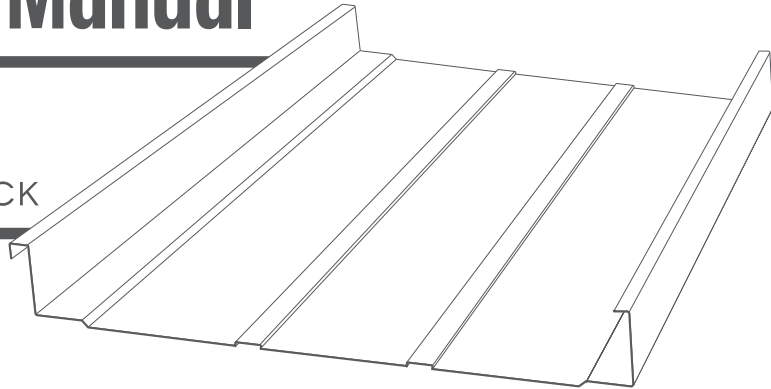

San Antonio • 2707 Castrovilla Rd • San Antonio, TX 78237 • (210) 227-727 McAllen • 2221 Austin Ave • McAllen, TX 78501 • (956) 627-2966
Dallas • 11569 Goodnight Ln • Dallas, TX 75229 • (972) 331 6800 Houston • 6460 Langfield Road • Houston, TX 77092 • (713) 944-4480

www.saqualitymetals.com

Quality Metals © ALL RIGHTS RESERVED 2023.

IMPORTANT NOTICE

THIS MANUAL CONTAINS SUGGESTIONS AND GUIDELINES ON HOW TO INSTALL THE SUBJECT QUALITY METALS ML-150 PANEL AND TRIM DETAILS. THE CONTENTS OF THIS MANUAL INCLUDE THE GUIDELINES THAT WERE IN EFFECT AT THE TIME THIS PUBLICATION WAS ORIGINALLY PRINTED. IN AN EFFORT TO KEEP PACE WITH THE EVER CHANGING CODE ENVIRONMENT, QUALITY METALS RETAINS THE RIGHT TO CHANGE SPECIFICATIONS AND/OR DESIGNS AT ANY TIME WITHOUT INCURRING ANY OBLIGATIONS. TO INSURE YOU HAVE THE LATEST INFORMATION AVAILABLE, PLEASE INQUIRE OR VISIT OUR WEBSITE. APPLICATION AND DESIGN DETAILS ARE FOR ILLUSTRATIVE PURPOSES ONLY AND MAY NOT BE APPROPRIATE FOR ALL ENVIRONMENTAL CONDITIONS AND/OR BUILDING DESIGNS. PROJECTS SHOULD BE ENGINEERED AND INSTALLED TO CONFORM TO APPLICABLE BUILDING CODES, REGULATIONS AND ACCEPTED INDUSTRY PRACTICES.

READ THIS MANUAL COMPLETELY PRIOR TO BEGINNING THE INSTALLATION OF QUALITY METALS ML-150 ROOFING SYSTEM.

ALWAYS INSPECT EACH AND EVERY PANEL AND ALL ACCESSORIES BEFORE INSTALLATION, NEVER INSTALL ANY QUALITY METALS PRODUCT IF ITS DAMAGE, NOTIFY QUALITY METALS IMMEDIATELY IF ANY PRODUCT IS NOT ACCORDING TO SPECIFICATION OR HAS BEEN DAMAGE.

INTRODUCTION

The **ML-150** Standing Seam System is an architectural panel designed for non-structural applications. This product incorporates a fixed and floating clip with an interlocking system, allowing panels to be installed in a single direction from a designated starting point.

The **ML-150** panel offers the leak resistance and aesthetic appeal characteristic of traditional standing seam systems. The clip system, in conjunction with screw attachments, facilitates thermal expansion and contraction, ensuring ease of panel movement with temperature fluctuations.

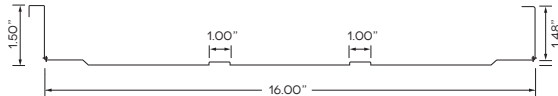

APPLICATIONS

Meticulously crafted for residential and commercial applications. The **ML-150** system boasts a simplified installation process, making it accessible for a range of projects.

What sets this system apart is its symmetrical visual aesthetics, presenting a non-directional appearance that enhances the overall design harmony of any structure.

SPECIFICATIONS

Gauges: 24 (standard), 22 and 26 (optional)
 Coatings: Galvalume[®], Storm Armor (Durapon 70[®], Ceranamel[®]).
 Substructure: Plywood or OSB to be a nominal 5/8 inch thick, open framing and metal decking.

WIDTHS

Actual Panel Coverage (Width): 16" Max.
 Minimum Slope = 1/2":12"

LENGTHS

The **ML-150** Panels are offered in standard lengths ranging from 4' to 40'. Extended lengths beyond 40' necessitate supplementary handling, packaging, and shipping considerations, potentially incurring an additional handling charge. Continuous roll-formed lengths obviate the necessity for panel lap joints.

DESIGN

The **ML-150** panel features a completely standing seam roofing system, ensuring a sleek and durable solution for your roofing needs.

With its low-maintenance requirements and ease of installation, the **ML-150** panel is suitable for both new construction and re-roofing projects, providing versatility and reliability for any application.

TESTING

UL-790 Fire Test of Roof Coverings, Class A,B, C.
UL-2218 For impact Resistance Class4.
UL 580 Uplift Resistance Class 90.

INSTALLATION

The **ML-150** panel features a fixed and floating clip system. With its standing seam design, field seaming is necessary. Weathertight Warranty is available for this product. Underlayment is required for optimal performance.

OIL CANNING

Offset, striations, and pencil ribs enhance structural integrity while minimizing the occurrence of oil canning.

TOOLS AND EQUIPMENT

The installer must possess previous experience and proficiency in working with metal roofing, including familiarity with the tools listed below and their respective applications.

- Caulking Gun
- Snips
- Cordless Screw Gun
- Pop Rivet Tool
- Tape Measure
- Hemming Tool
- Electrical Extension Cord
- Heavy Gloves
- Safety Glasses.
- Roof Seamer Machine

MECHANICAL HANDLING

FORKLIFT

A forklift may be utilized for panels up to 20 feet in length. Ensure that the forks are fully extended to their maximum separation. Avoid transporting open crates. When moving crates over uneven terrain or for extended distances, supplementary support for the panel load is necessary.

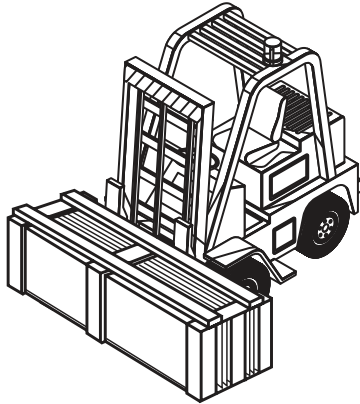

CRANE

A crane is recommended for hoisting panels exceeding 20 feet in length. Utilize a spreader bar to ensure uniform weight distribution across the lifting points. As a general guideline, avoid leaving more than one-third of the panel length unsupported during lifting operations. Use canvas or nylon slings for panel hoisting. Avoid the use of cables or chains as they may cause damage to the panels.

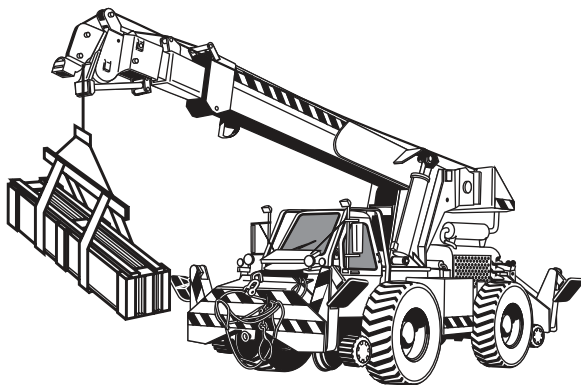

CAUTION

IMPROPER LOADING AND UNLOADING OF CRATES MAY LEAD TO BODILY HARM AND/OR MATERIAL DAMAGE. QUALITY METALS BEARS NO RESPONSIBILITY FOR ANY BODILY INJURIES OR MATERIAL DAMAGES RESULTING FROM IMPROPER LOADING AND UNLOADING PRACTICES.

GENERAL HANDLING

Each crate requires careful handling to avoid damage, ensuring the prevention of panel bending or finish abrasion. Follow these guidelines for proper care during crate unloading and handling to mitigate panel damage:

1. Crates must remain intact during handling until individual panels within each bundle are ready for installation.
2. Never lift crates by the banding.
3. Lift each crate as close to its center of gravity as possible. When lifting crates with a crane, use a spreader bar of appropriate length and nylon band slings.
4. Avoid using wire rope slings to prevent panel damage.
5. Depending on panel length, some crates may be lifted by a forklift. Ensure the forks are spread apart to their maximum spacing, and the load is centered on the forks to prevent scratching adjacent panels.
6. Avoid lifting panels by their ends; instead, lift them along their longitudinal edge in a vertical position.
7. For panels exceeding 10 feet in length, enlist two or more individuals to lift the panel along the same edge.
8. After opening crates, handle individual panels with care to prevent buckling or coating damage. When removing a panel from a crate, avoid sliding it over another panel. Instead, "roll" the individual panels out of the crate to minimize the risk of damage.

MANUAL HANDLING

It is imperative to wear soft gloves while handling panels. Panels should never be lifted by their ends. Instead, lift the panel along its longitudinal edge and carry it in a vertical position, avoiding a flat orientation.

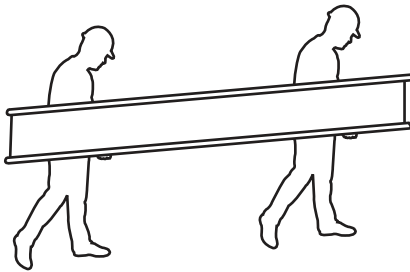

6'-8' MAX

FOOT TRAFFIC

Foot traffic poses a risk of panel distortion and finish damage. It is essential to minimize traffic over the installed system. In cases where continuous foot traffic is required for maintenance, the installation of permanent walkways is recommended.

During installation, if continuous foot traffic is unavoidable, utilize walking platforms to prevent panel damage. Avoid walking directly on the ribs, as this may cause harm to the panels.

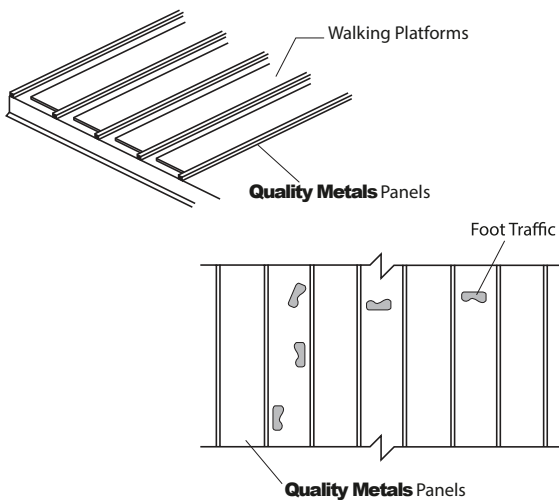

CAUTION

ALL RELEVANT SAFETY REGULATIONS, INCLUDING THOSE OUTLINED BY OSHA, MUST BE ADHERED TO THROUGHOUT THE PANEL INSTALLATION PROCESS.

FIELD CUTTING

For field cutting ML-150 panels, it is advisable to use snips or an electric tool of the "nibbler" type.

Utilizing a skill saw may result in the generation of metal chips, which can damage the finish and reduce the lifespan of the product.

To mitigate this issue, one approach is to flip the panels over during cutting, enabling the removal of metal chips from the back side of the panels.

CAUTION

ALL PRODUCT SURFACES MUST REMAIN CLEAR OF DEBRIS AT ALL TIMES. ONCE INSTALLED, SURFACES SHOULD BE WIPED CLEAN AT THE CONCLUSION OF EACH WORK PERIOD. AVOID CUTTING PANELS OVER METAL SURFACES, AS METAL SHAVINGS MAY ACCUMULATE AND LEAD TO SURFACE RUSTING, THEREBY VOIDING THE WARRANTY.

CAUTION

WHEN CUTTING METAL PANELS, IT IS IMPERATIVE TO WEAR GOGGLES FOR EYE PROTECTION.

DESIGN CONSIDERATIONS AND CALCULATIONS

Proper design and installation of vapor barriers and ventilation systems are crucial to preventing condensation and the associated problems of moisture damage and reduced insulation efficiency.

Condensation occurs when air containing moisture comes into contact with a surface whose temperature is equal to or below the dew point of the air.

This phenomenon is not exclusive to metal buildings; rather, it is a common issue in various types of construction.

In addition to providing resistance to heat transfer, insulation also serves to mitigate condensation formation on cold surfaces, whether inside the building or within the wall/roof system cavity. The arrangement of the building's insulation system and vapor retarder falls under the purview of the building designer.

Here are some fundamental guidelines to help manage condensation in metal buildings:

1. Insulation should feature a vapor retarder facing the "warm" side, typically towards the building's interior.
2. The insulation thickness must be carefully determined to maintain the vapor retarder's temperature above the interior dew point, even under extreme outside temperature conditions.
3. All perimeter conditions, seams, and penetrations of the vapor retarder must be effectively sealed to create a continuous membrane that resists the passage of water vapor.
4. Building ventilation, whether facilitated by gravity ridge vents, power-operated fans, or other means, plays a significant role in condensation reduction. Air movement towards the exterior of the building lowers the interior vapor pressure.

In buildings with an attic space or those retrofitted with a metal roof system, vents should be strategically placed at both ends of the eave and peak of the roof to prevent moisture buildup in the attic space.

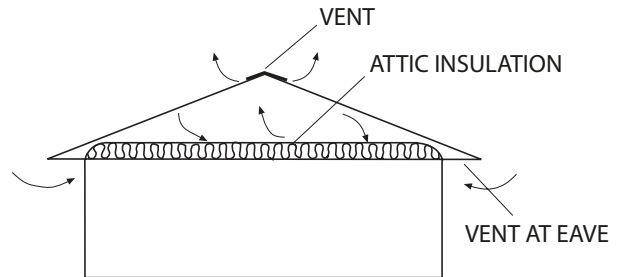

TOUCH-UP PAINT

All painted panels and flashings are equipped with a factory-applied baked-on finish. However, handling and installing panels may occasionally result in minor scratches or nicks to the paint finish.

Touch-up paint is available in matching colors for such instances. It is recommended to use a small brush for precise application of touch-up paint to areas in need of repair.







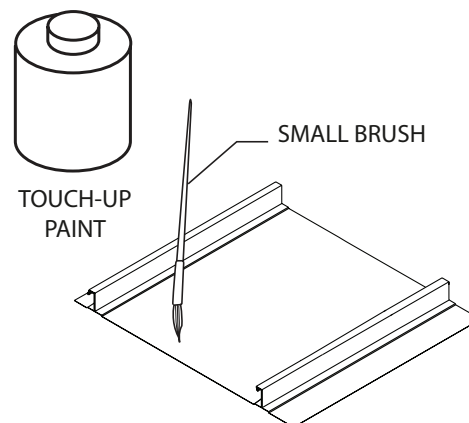

It is important to note that touch-up paint does not possess the superior chalk and fade resistance characteristic of the factory-applied paint finish. As a result, it may discolor at an accelerated rate.

Periodic touch-up painting may be necessary to maintain color consistency. However, it's essential to understand that there is no warranty on touch-up paint in terms of color matching, as the paint processes may differ.

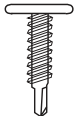
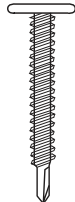

Furthermore, the use of aerosol paint is not recommended due to the potential for overspray, which may cause unintended damage.

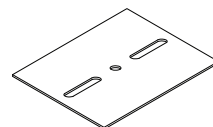
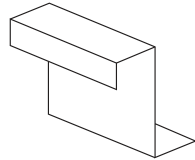
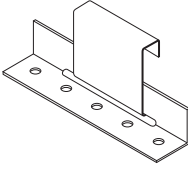
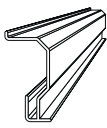
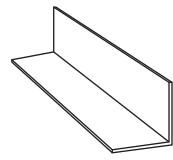
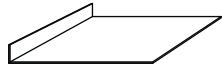

Accessories

			
1/4 14 x 7/8" Hex Head Lap Tek Screw <i>metal to metal</i>	#10 x 1-1/2" Hex Head Woodmate Screw <i>Metal to Wood</i>	#10 x 1" Pancake Head Woodscrew	2" Pancake Head Woodscrew
			
1" Pancake Head Tek Screw	2-1/2" Pancake Head Tek Screw	#10 x 1" Hex Head Woodscrew	1/4 - 14 X 7/8 "Lap" Longlife <i>W/washer Metal to Metal</i>
			
1/4 - 14 - 14 X 1 1/4" Longlife <i>W/washer Metal to Metal</i>	1/4 - 4 - DP#3 Concealor <i>Metal to Metal</i>	Standard Bearing Plate <i>5" x 4"</i>	ML-150 Fixed Clips
			
ML-150 Floating Clips <i>Two pieces UL approved</i>	Rake Retainer	Parapet Wall Support <i>Galvanized</i>	Rake Support

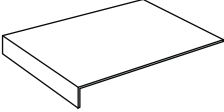
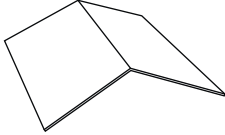
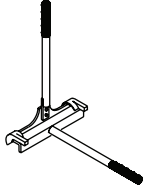
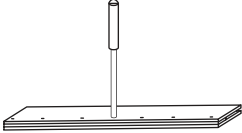
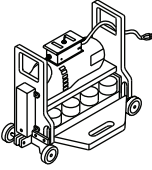
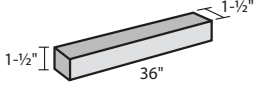
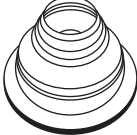
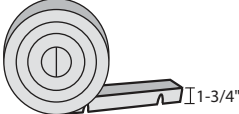
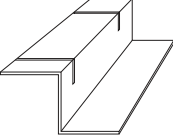
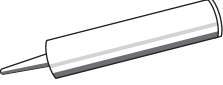
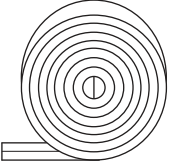
Accessories

			
Eave Support <i>Galvanized</i>	Ridge - Valley Support <i>Galvanized</i>	Hand Crimper	Hemming Tool
	 1-1/2" x 36" x 1-1/2"		 1-3/4"
Electric Seamer	Neoprene Universal Closure	Pipe Boot <i>(Various sized, heat treated & retro fit available)</i>	Vented Ridge Closure
			
Gutter Strap	Tube Sealant	Double Bead Butyl Tape <i>(7/8" x 3/16" x 40')</i>	Roll Valley

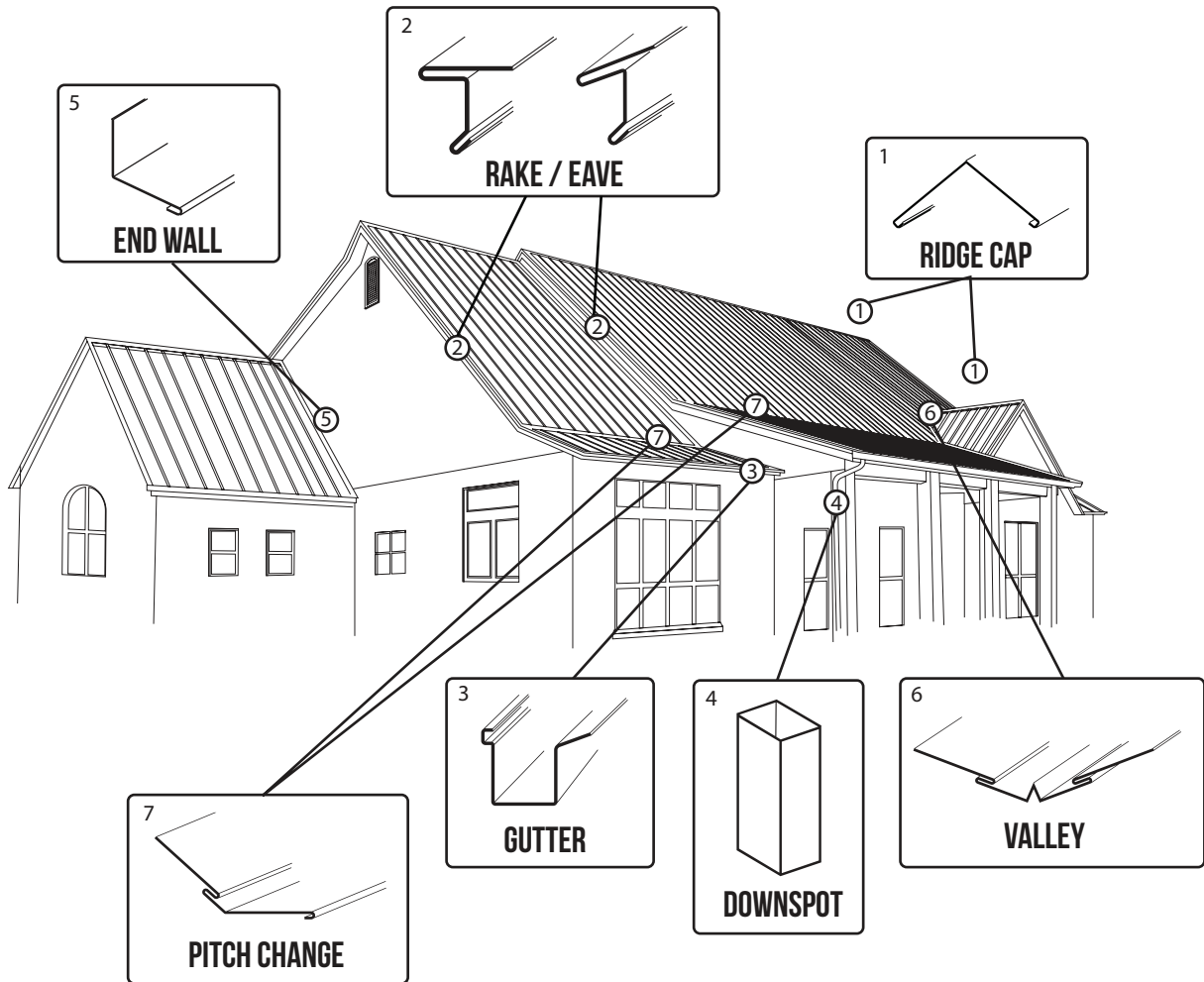

Installation

SEAMING PROCESS

The three drawings below illustrate the seaming process.

Step 1: Begin by installing clips over the male leg and fastening them securely to the substrate.

Step 2: Next, position the female leg of the adjoining panel onto the male leg/clip assembly.

Step 3: Finally, seam the panels together using either a mechanical or hand seamer. The seam can be a 90° degree seam, or a 180° degree (double) seam, which is optional but recommended for areas with high wind loads. Data from extensive wind uplift tests is available for different alloys to ensure optimal performance.

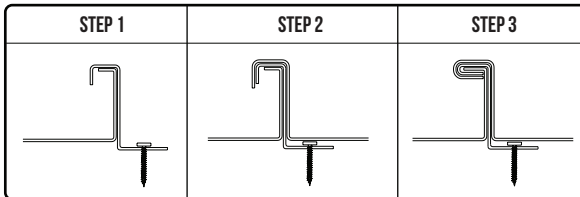
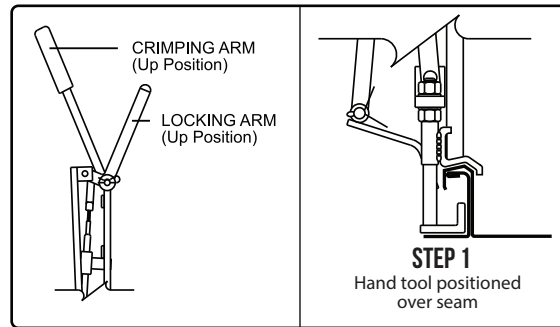

HAND CRIMPER

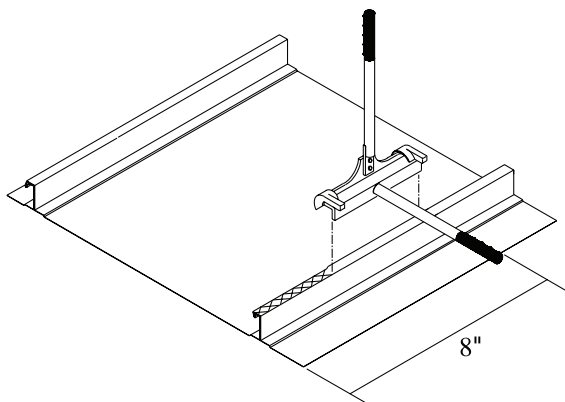

To start seaming, hand crimp first 8" of seam at eave, end lap, and ridge locations only.

Do not hand crimp at clip locations.

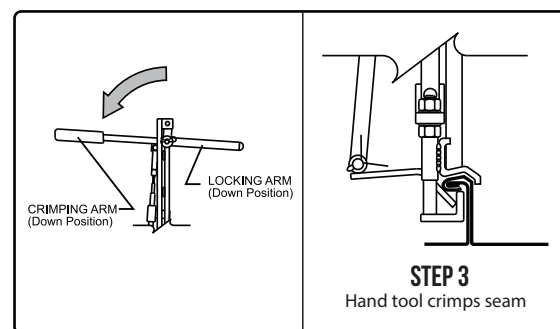
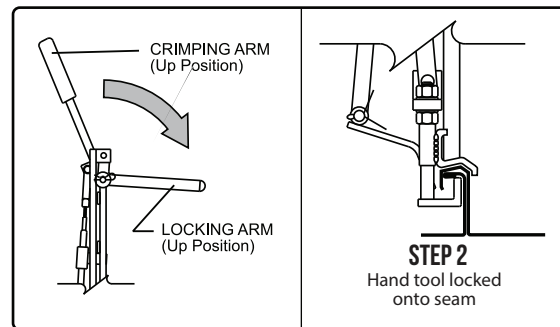

Installation

ELECTRIC SEAM

The electric seamer will run in one direction only. To determine the direction of the seamer, stand at the eave and look upslope. If the roof is being installed from left to right, the seamer will run upslope. If the roof is being installed from right to left, the seamer will run upslope. An orientation plate is on the seamer to assist you in placing it onto the seam properly. When the roof has endlaps, the panels will always be installed from right to left. When the roof slope is 6 on 12 or greater, panels must run from right to left.

To begin seaming, set seamer on seam with the locking bar up and to the open side of the seam. The rear wheels should be even with the edge of the roof panel. Push the locking bar down to engage the rooms and turn the seamer on.

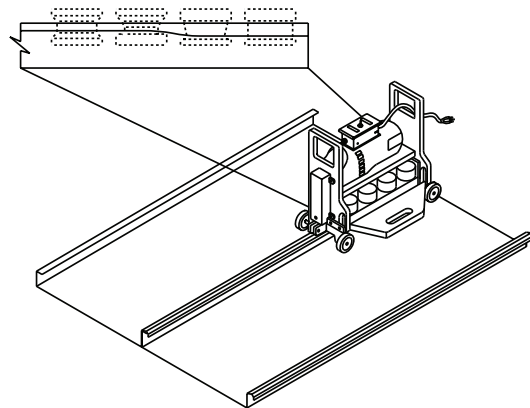
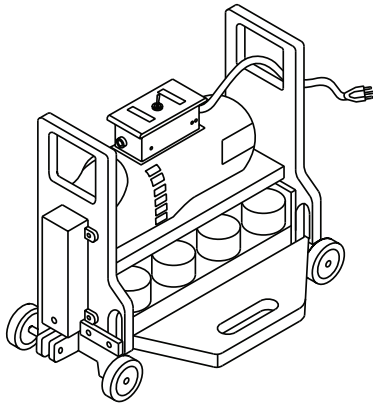

Stop seamer about one foot from end panels. Disengage locking bar and remove the electric seamer. Finish seam with hand tool.

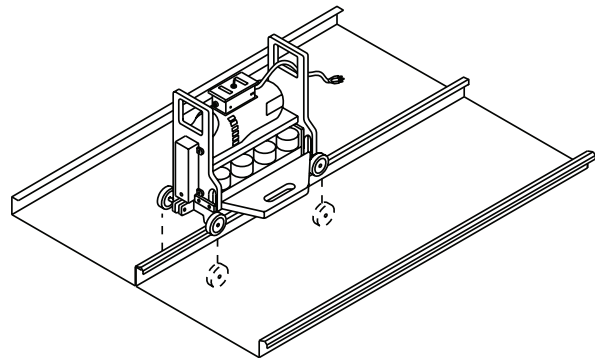
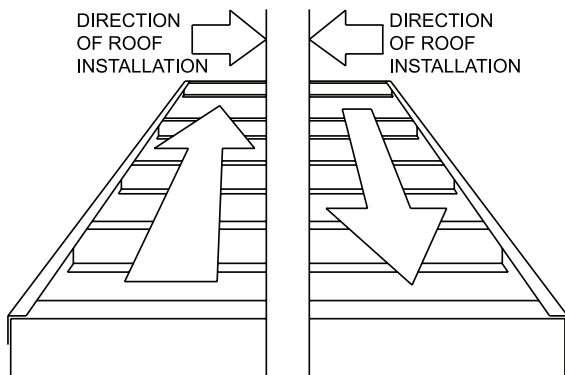

CAUTION

- Seamer operation should be closely supervised all times.
 - A safety line should be attached to the seamer.
- Do not entangle the electrical cords in the seamer tooling while is in operation.
This could cause serious injury or death to the operator and severely damage the seamer.
- Electrical cords should be 10-gauge to provide power to the seamer and never be over 200 feet from the electrical source.

Installation

HEM LENGTHS

A standing seam roof panel undergoes changes in length due to fluctuations in temperature. One end of the panel is fixed to the substrate, while the other end is free to move. The free end requires a hem that engages a cleat fixed to the substrate. This hem and cleat system allows the panel to move along the roof plane while keeping it flat.

Proper design of the hem and cleat is necessary to accommodate thermal movement. The length of the hem required at the end of a panel depends on the temperature range the panel experiences and the panel's length. Unless a precise analysis of temperature during installation compared to anticipated temperature changes is conducted, use the following equation and refer to the Thermal Movement Table.

During installation, ensure there is space at the end of the cleat. Make sure the hem is not tightly against the cleat, unless the panels are being installed in the coldest temperatures they will experience. Also, ensure that the lower edge of the hem will not contact any flashings when the panels contract.

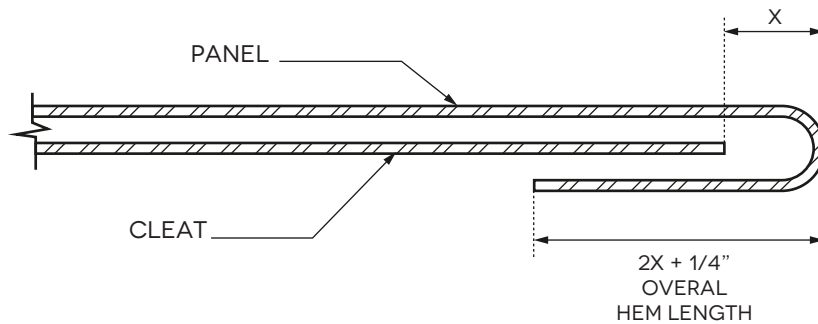

PANEL AND SUBSTRATE MATERIALS	PANEL LENGTH (FT)			REQUIRED IAR SPACE (X)
	10'	50'	100'	
<i>Steel on Rigid Insulation</i>	1/8"	1/2"	7/8"	
<i>Steel on Wood</i>	1/16"	3/8"	5/8"	
<i>Steel on Steel</i>	1/16"	3/8"	5/8"	
<i>Steel in Concrete</i>	1/16"	3/8"	1/2"	
<i>Aluminum or Rigid Insulation</i>	3/16"	7/8"	1 9/16"	
<i>Aluminum on Wood</i>	3/16"	11/16"	1 3/8"	
<i>Aluminum on Steel</i>	1/8"	5/8"	1 3/16"	
<i>Aluminum on Concrete</i>	1/8"	5/8"	1 1/4"	

This table assumes a temperature change of 100 °F for the panel and 50 °F for the substrate.

Installation

ML-150 OVER PLYWOOD OR OSB MIN 5/8"

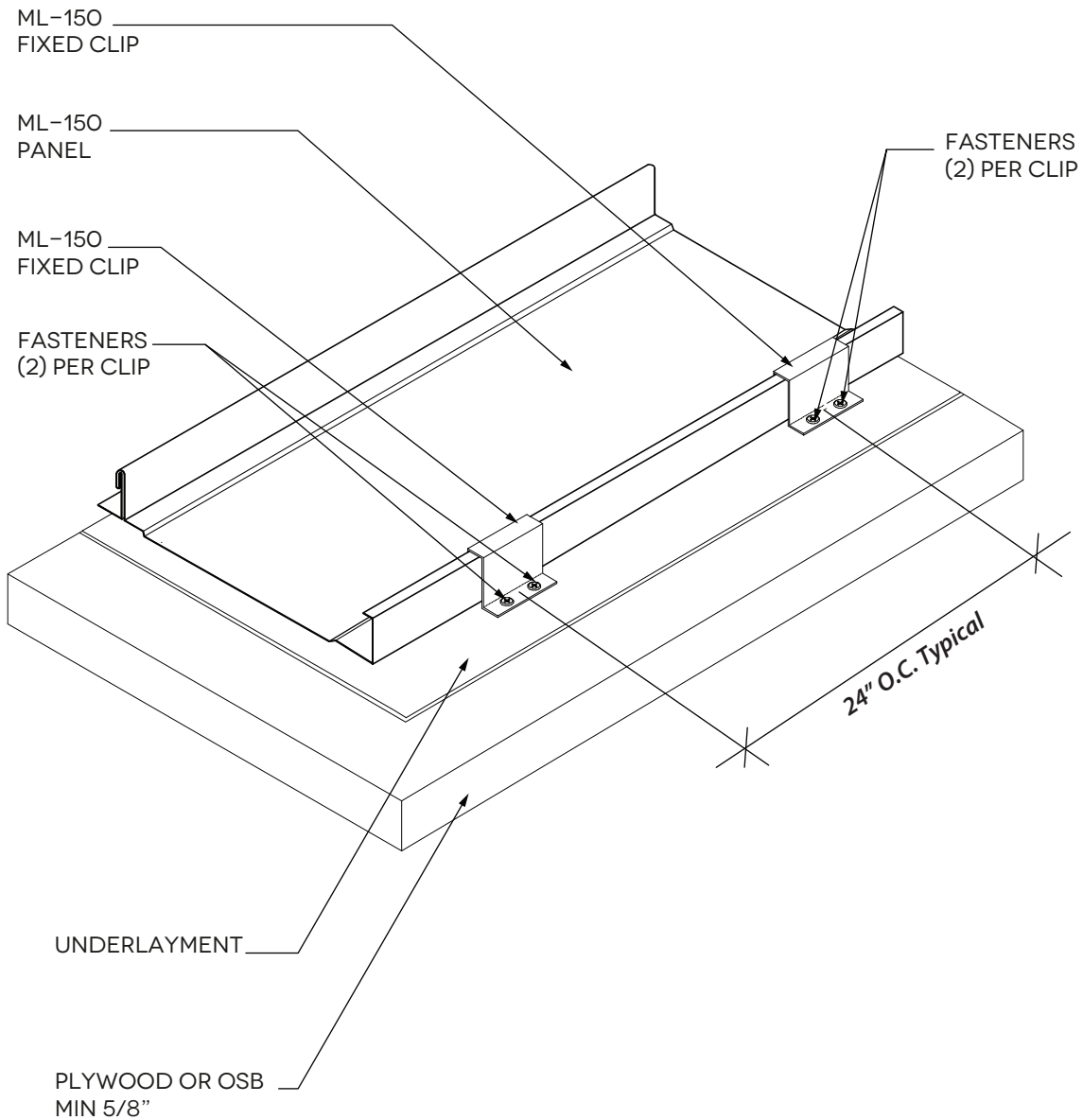

Installation

DRIP EDGE AT EAVE

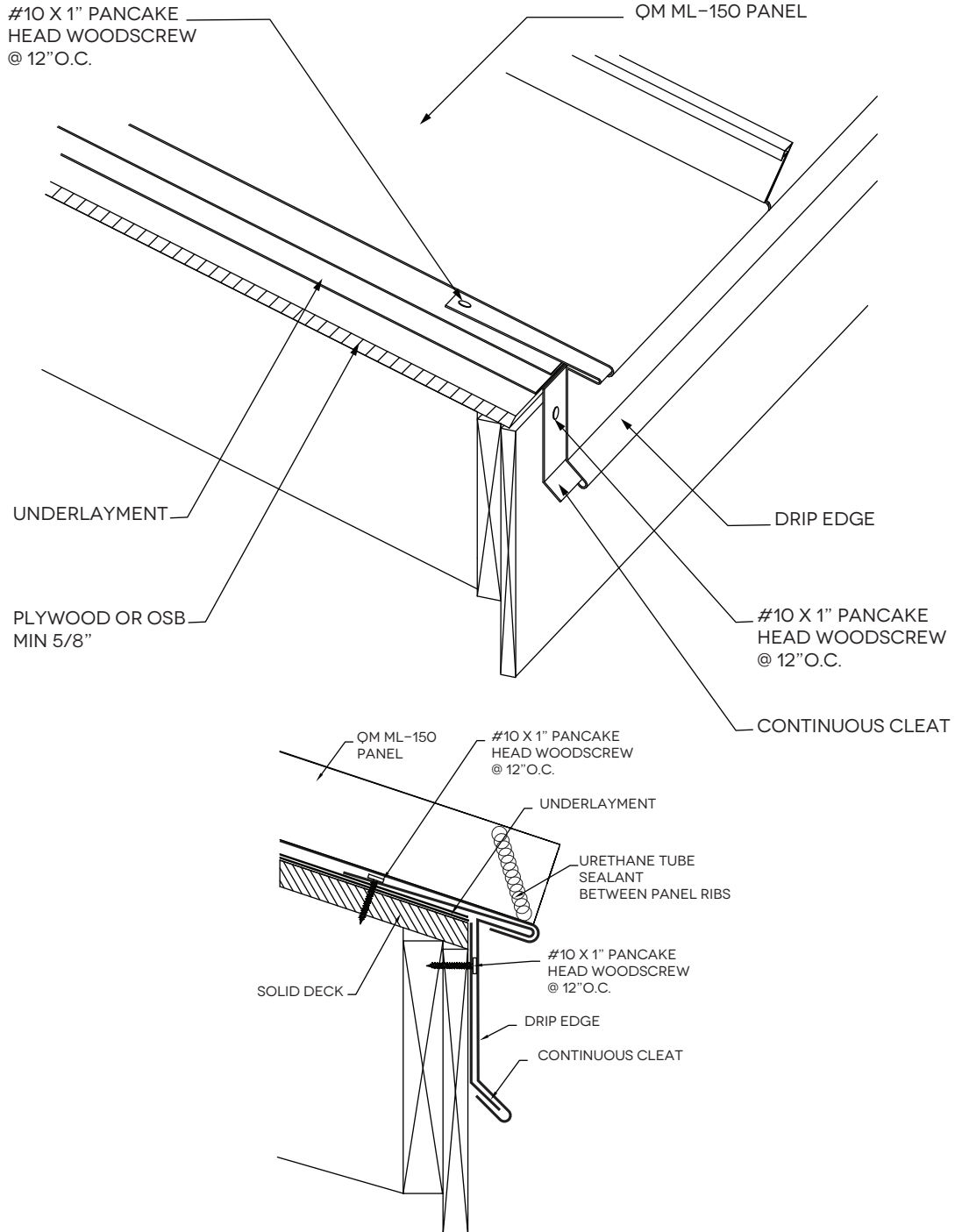

Installation

BOX GUTTER

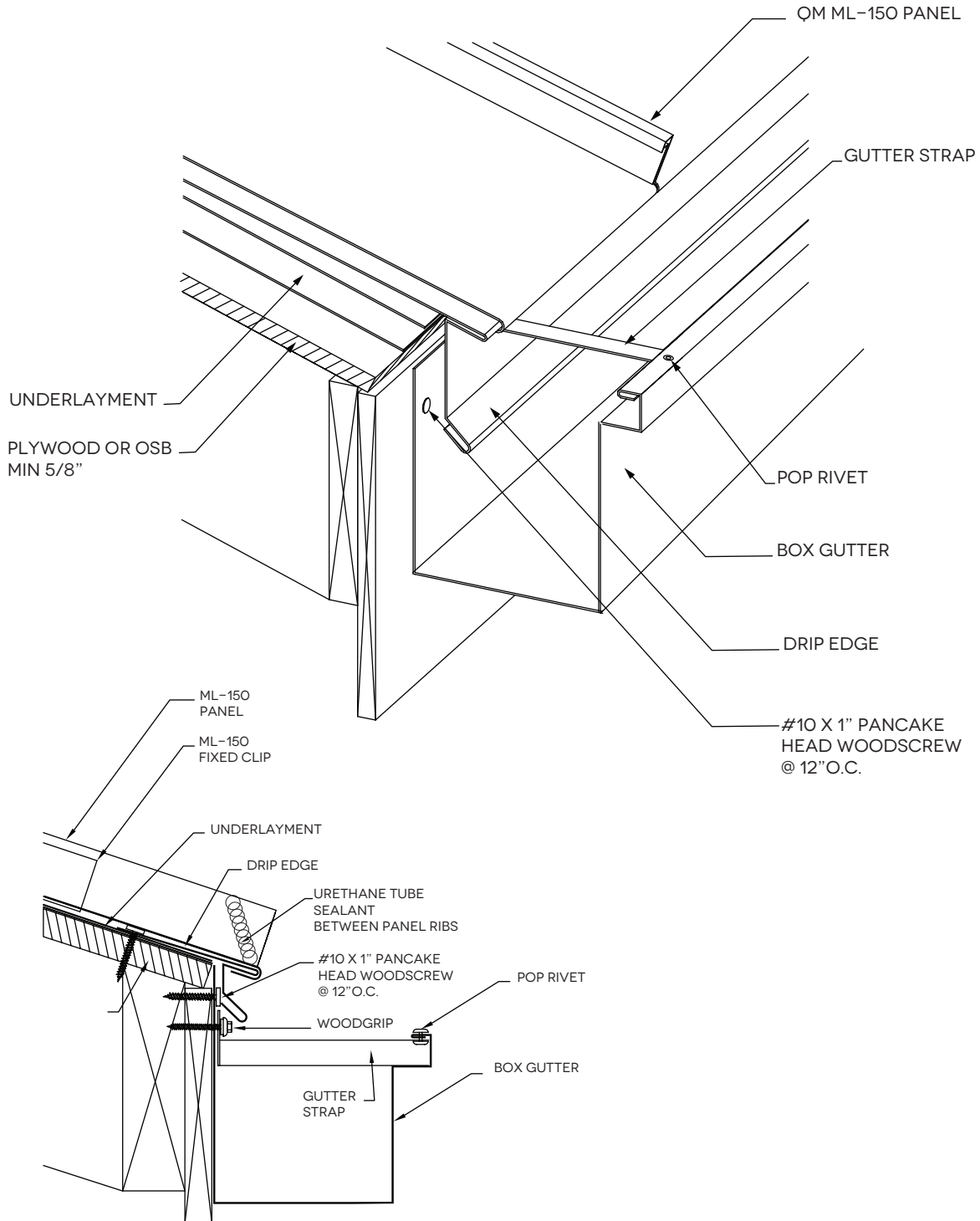

Installation

HANG ON BOX GUTTER

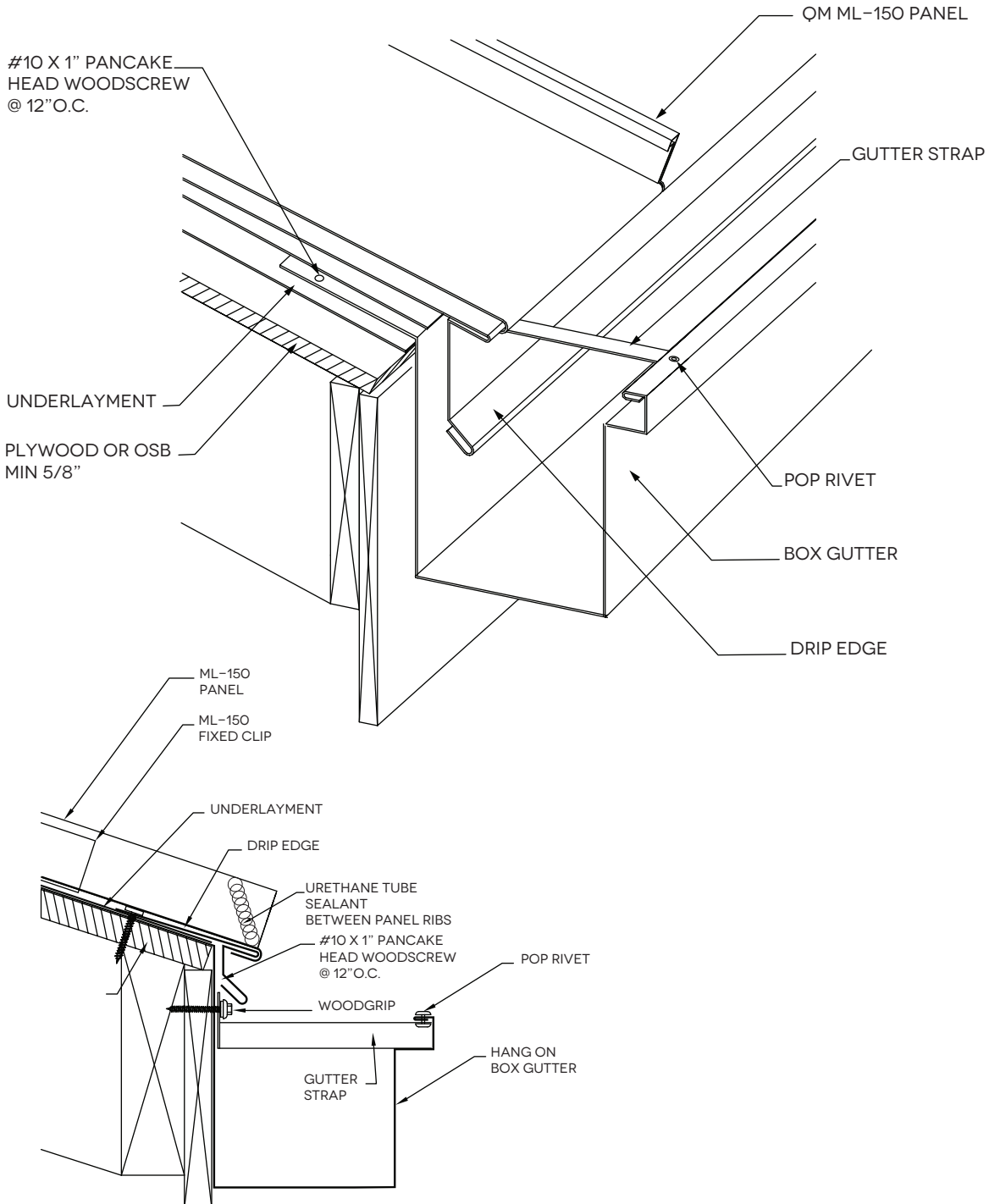

Installation

HIP DETAIL

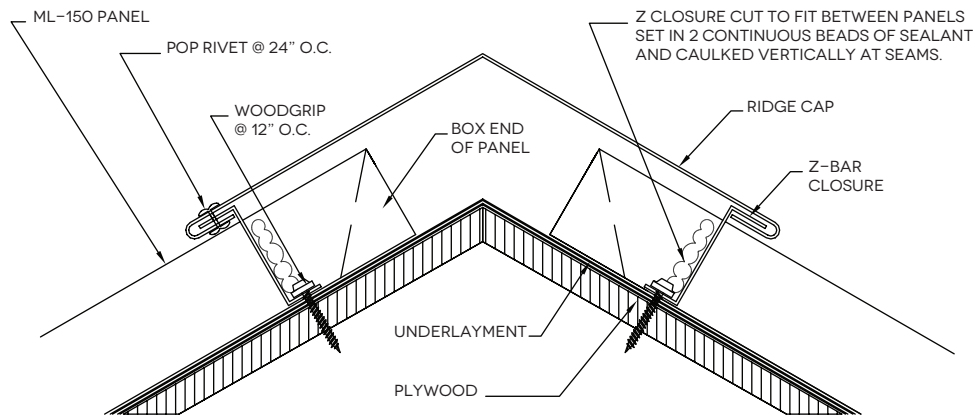
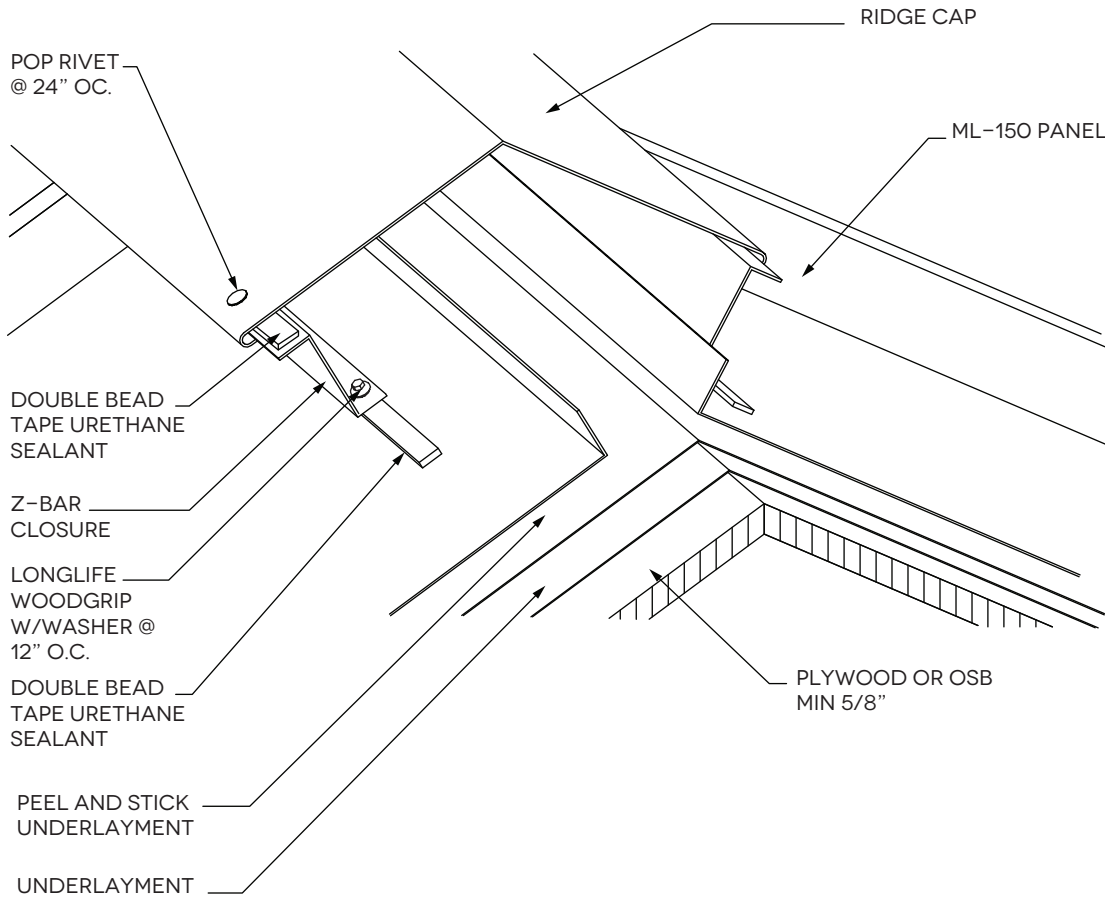

Installation

RIDGE CAP WITH METAL VENTED Z BAR

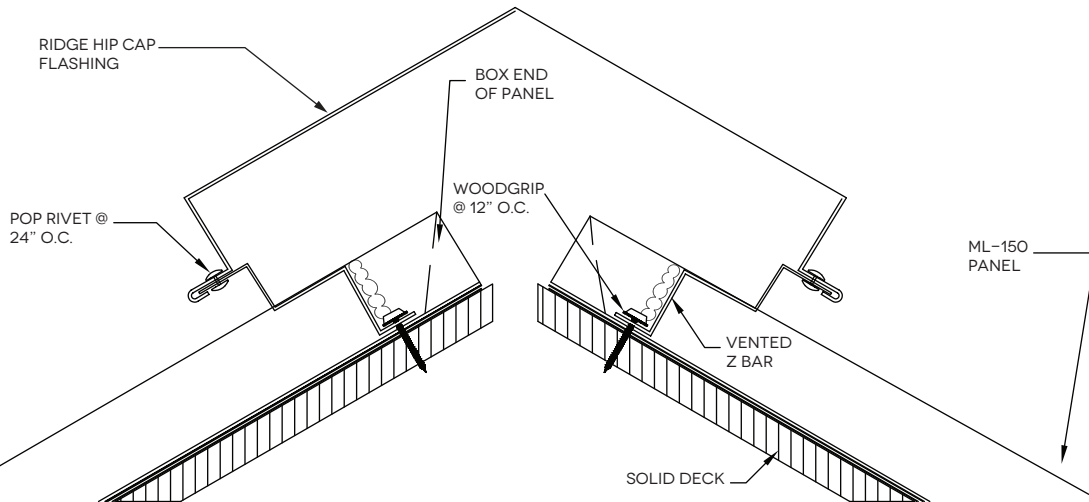
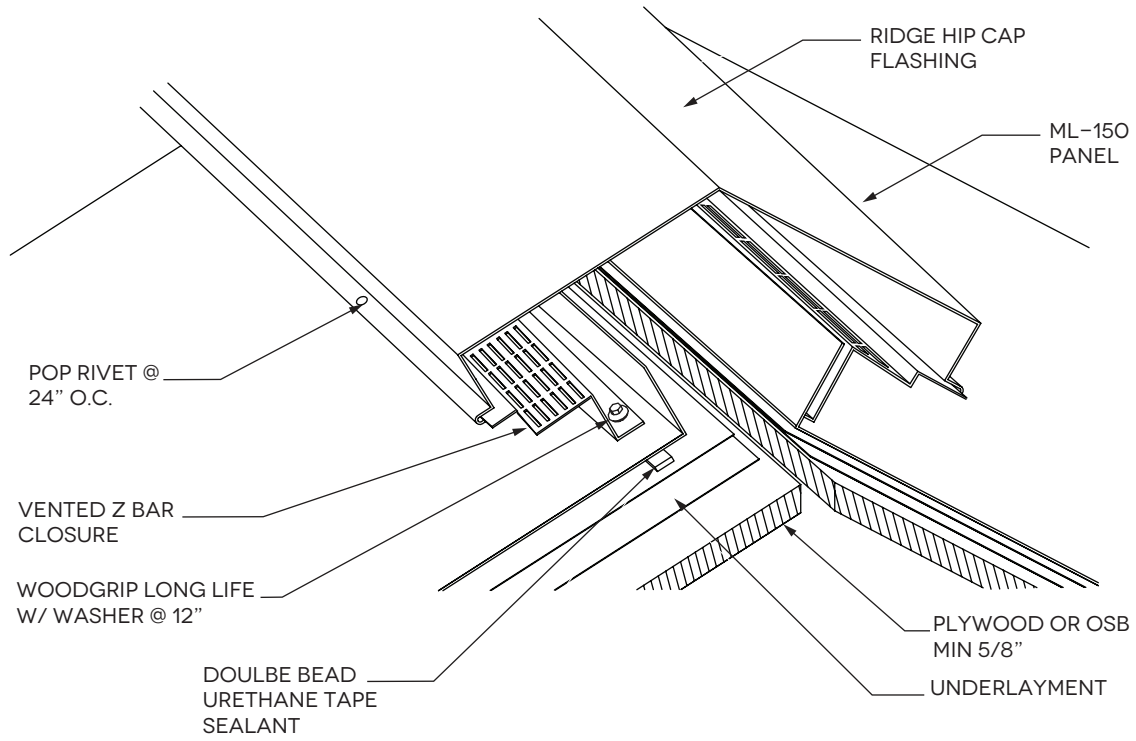

Installation

BOX RAKE

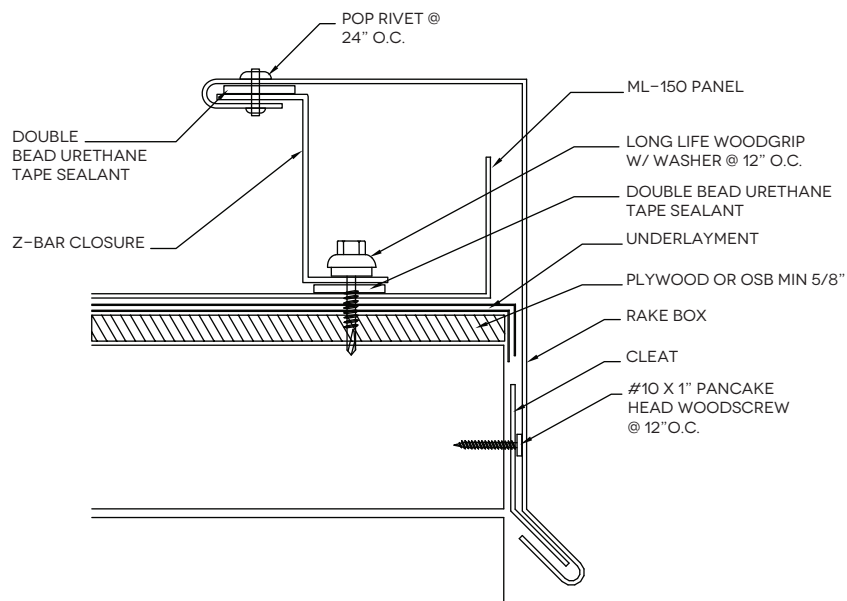
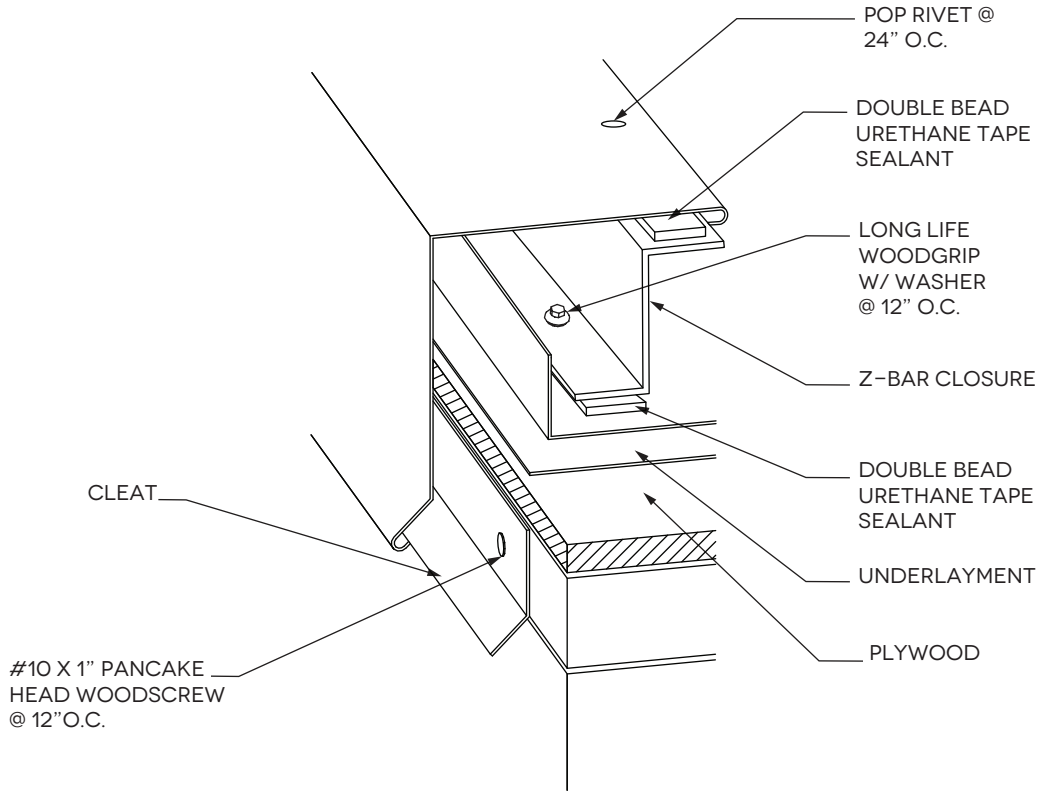

Installation

BOX RAKE WITH RAKE RETAINER

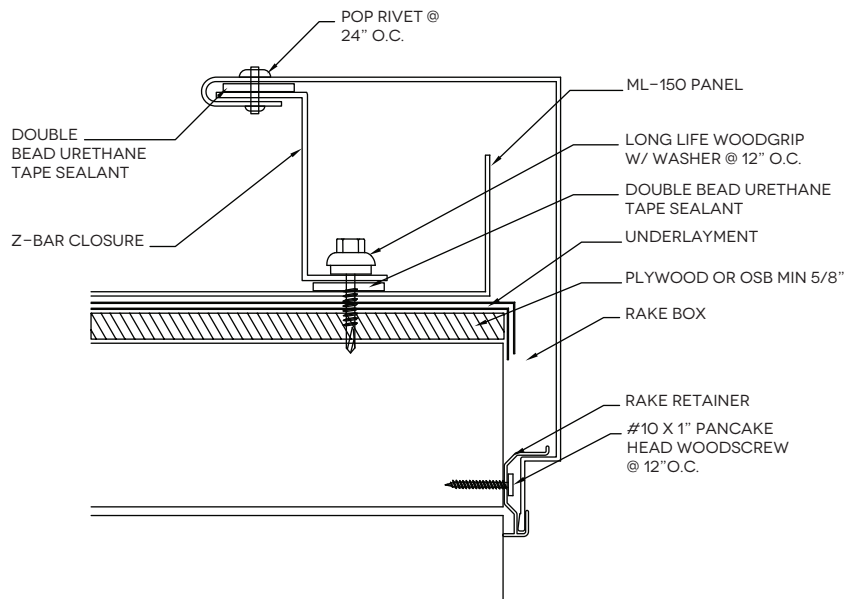
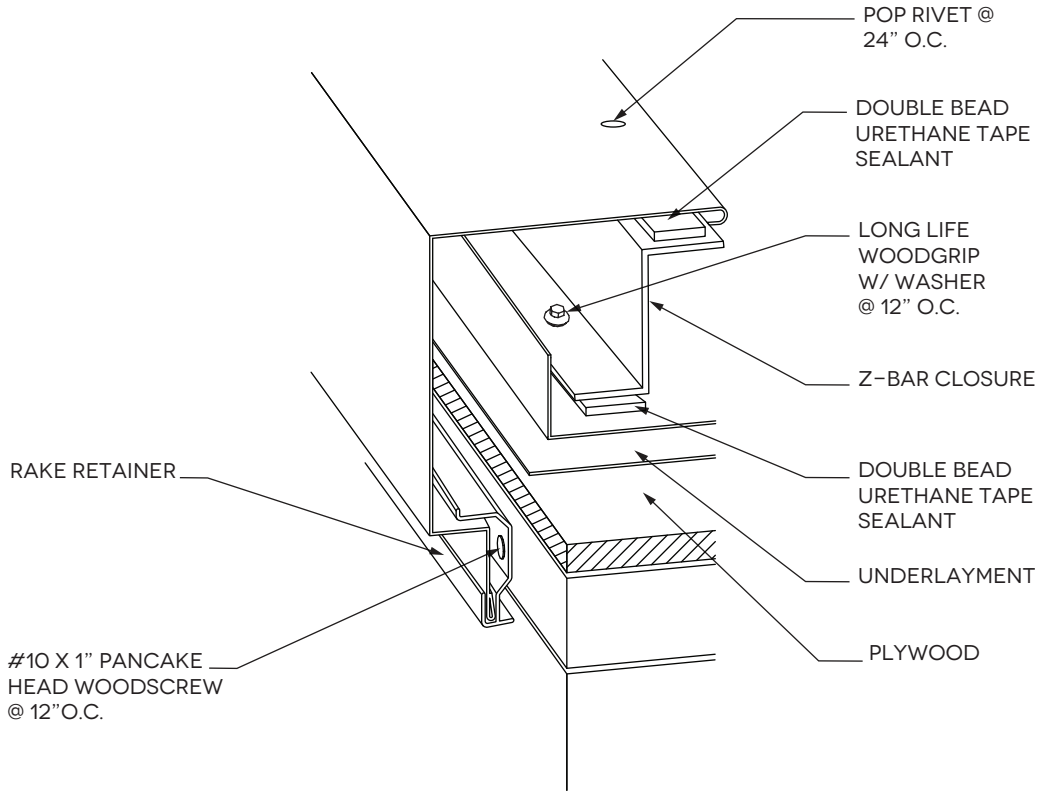

Installation

PEAK VALLEY WITH CLEAT

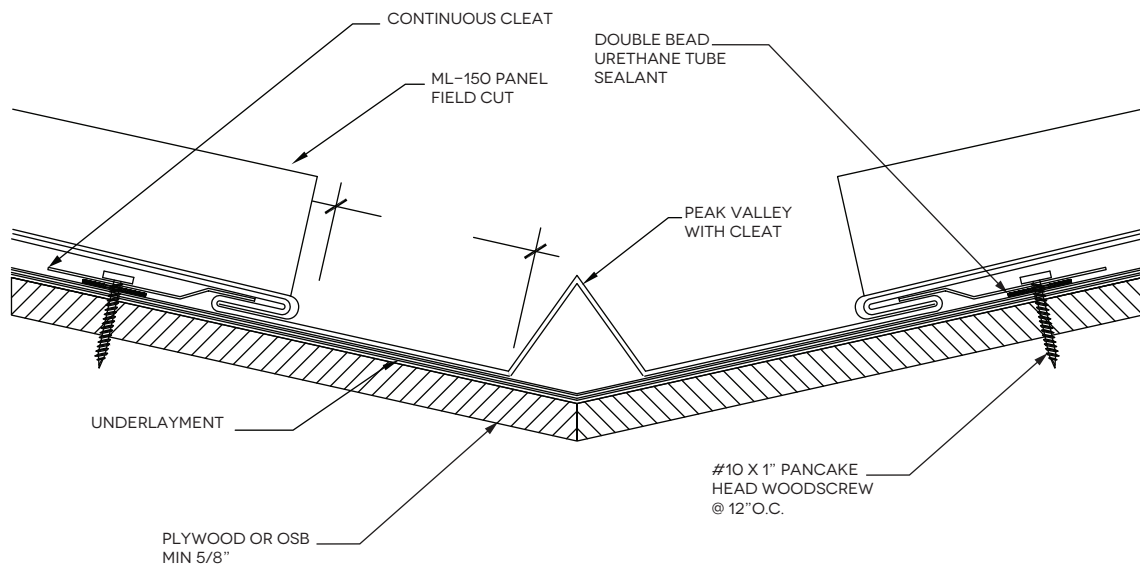
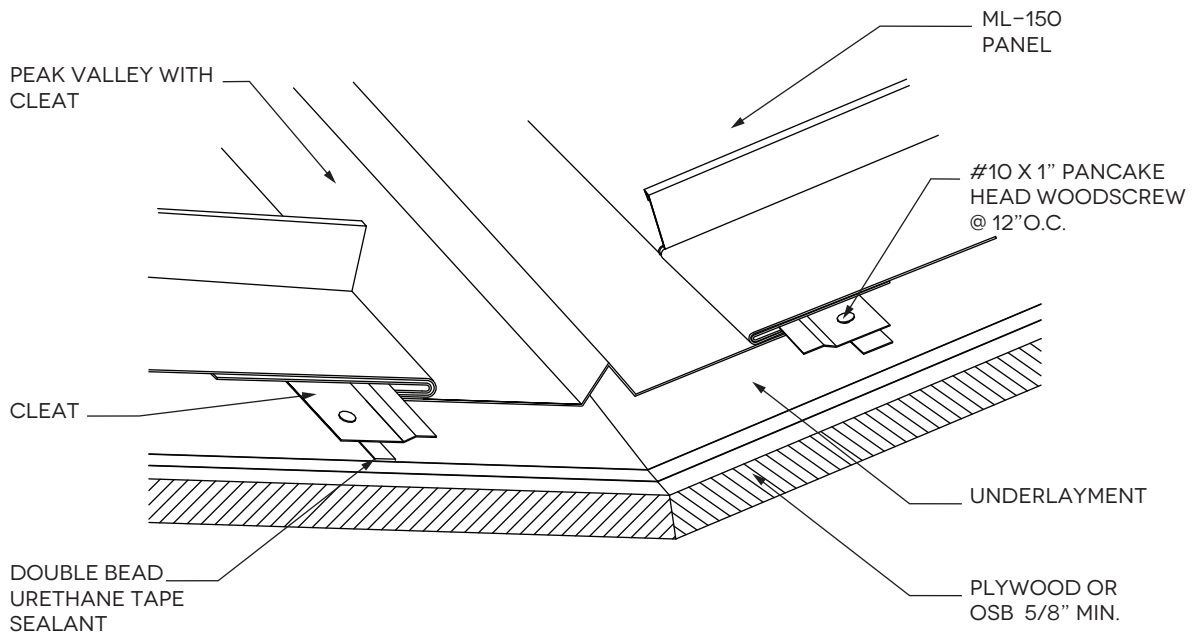

Installation

ENDWALL DETAIL

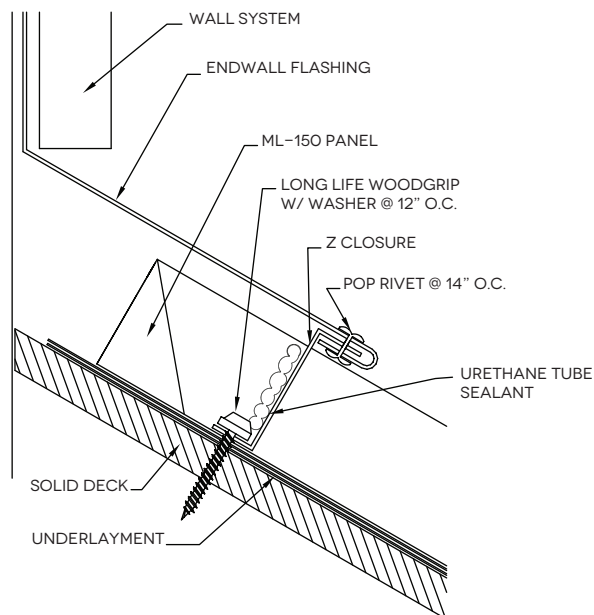
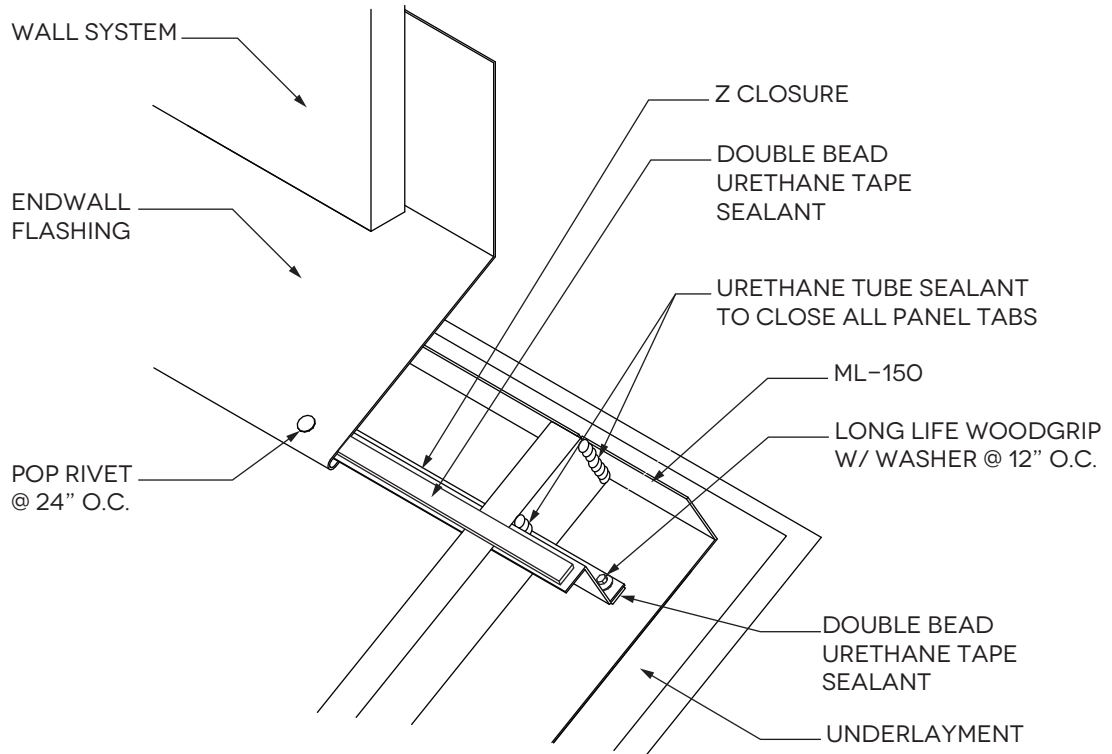

Installation

ENDWALL DETAIL

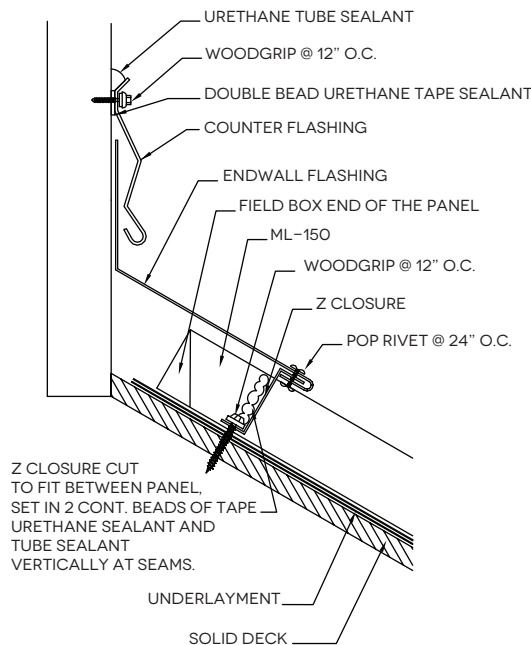
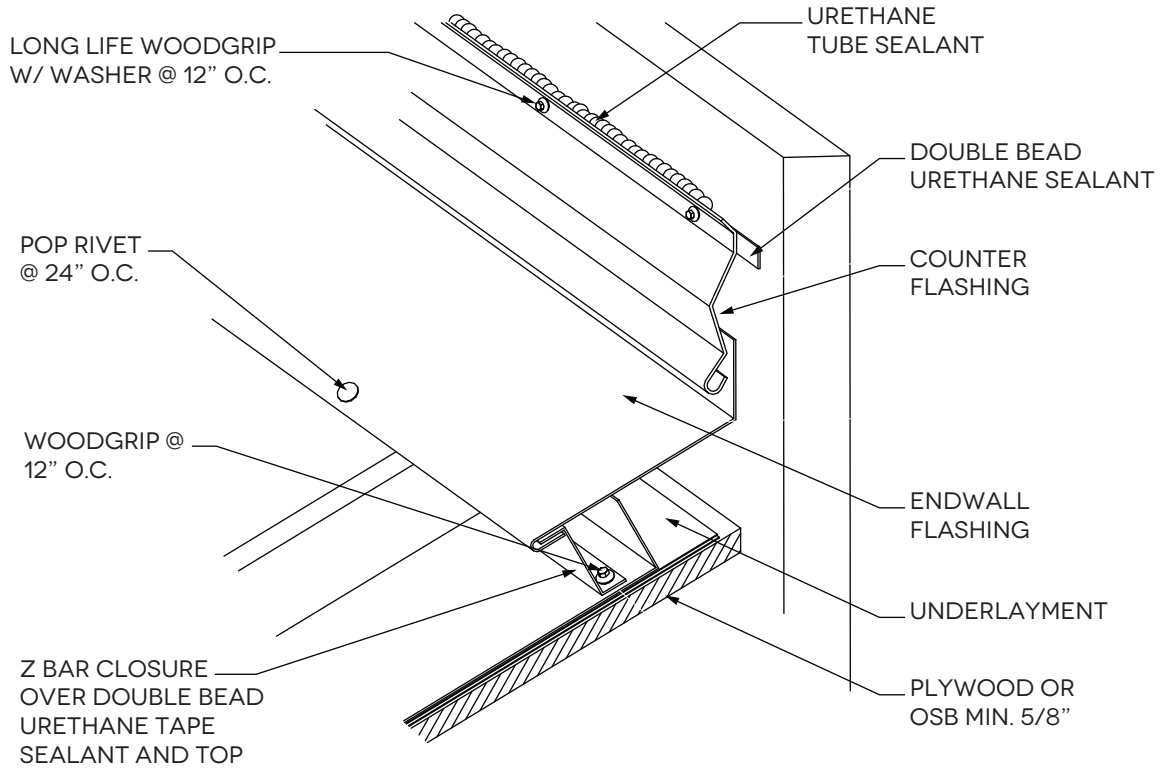

Installation

ENDWALL WITH REGLET DETAIL

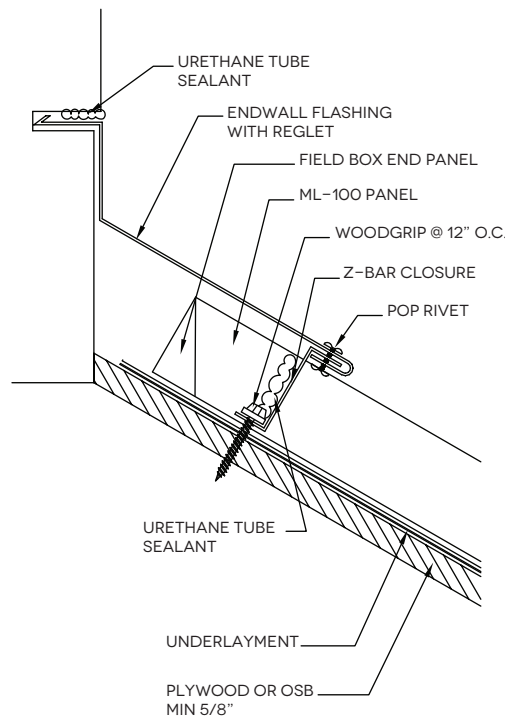
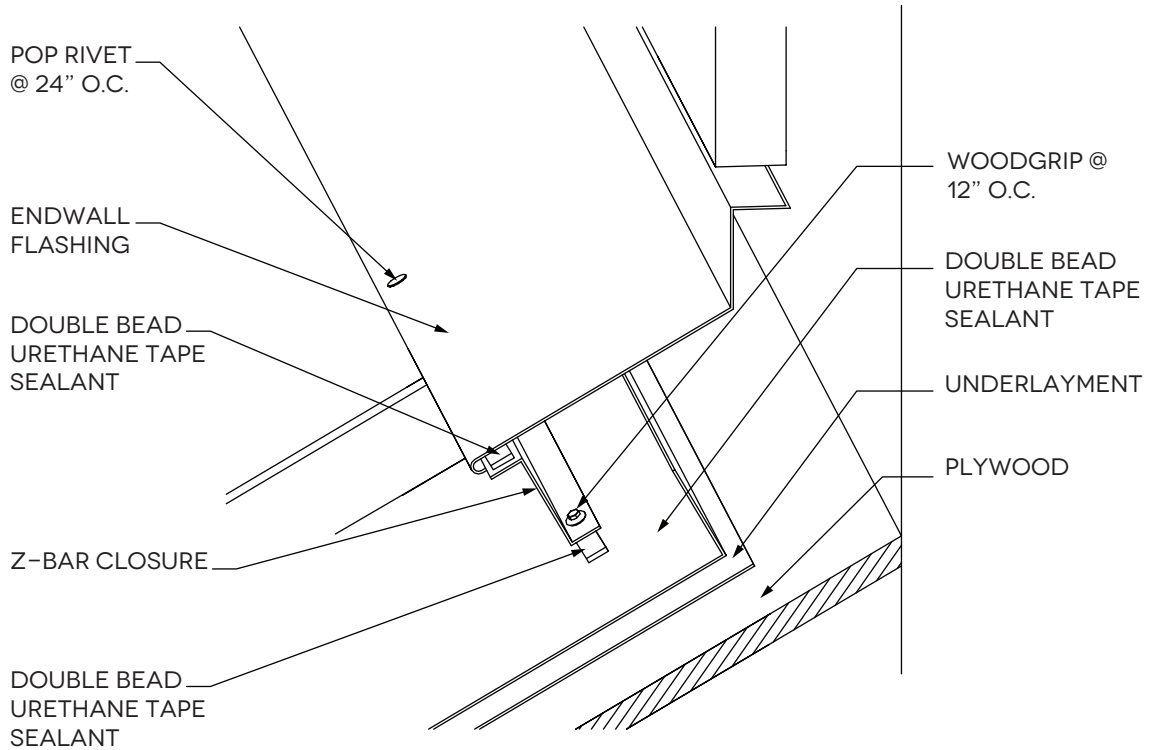

Installation

SIDEWALL WITH PARAPET RAKE WITH ALTERNATE COUNTER FLASHING

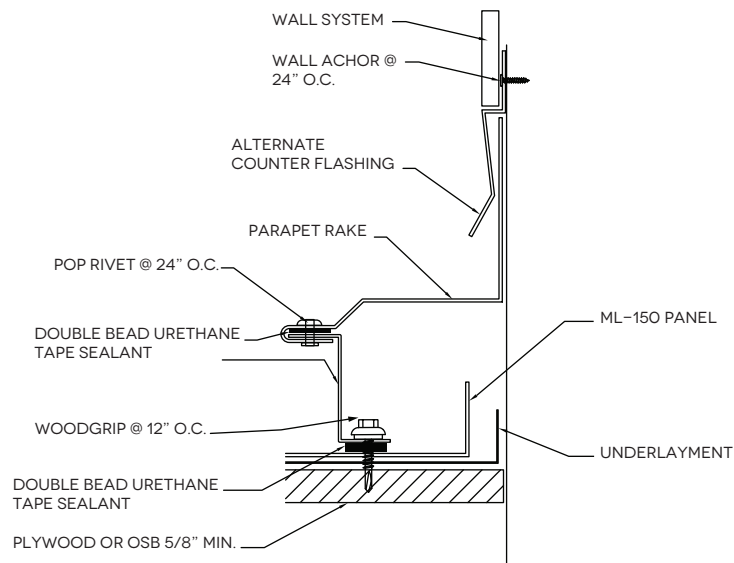
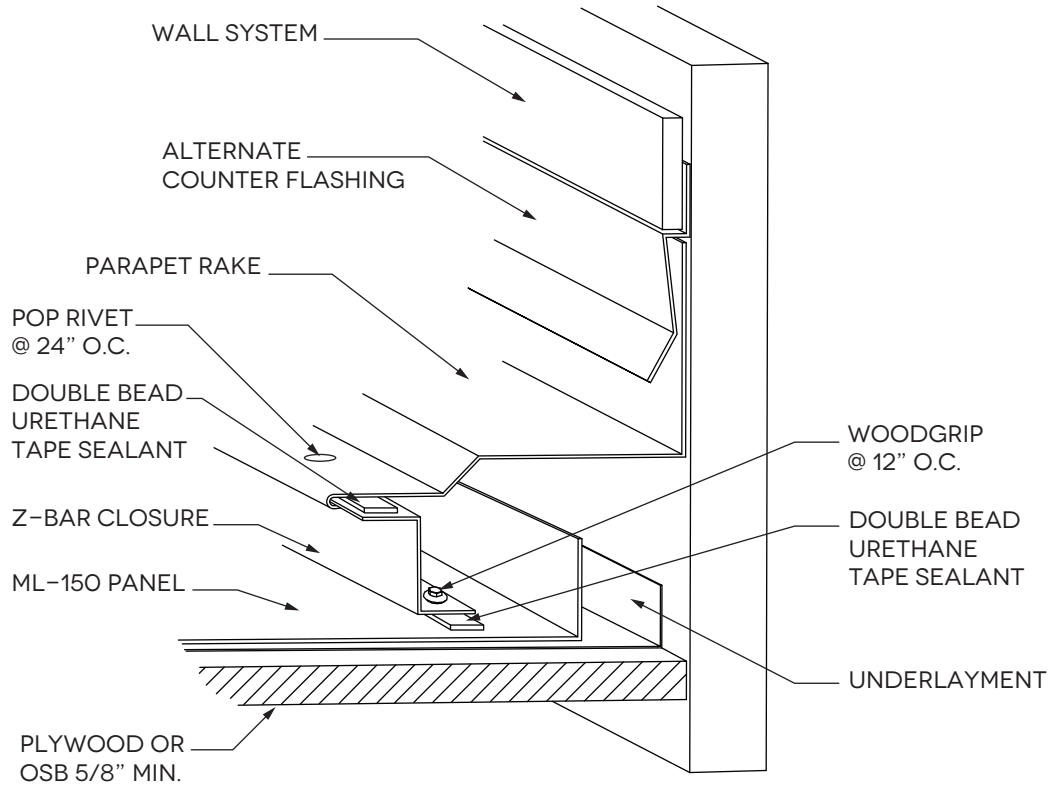

Installation

SIDEWALL WITH PARAPET RAKE AND COUNTER FLASHING

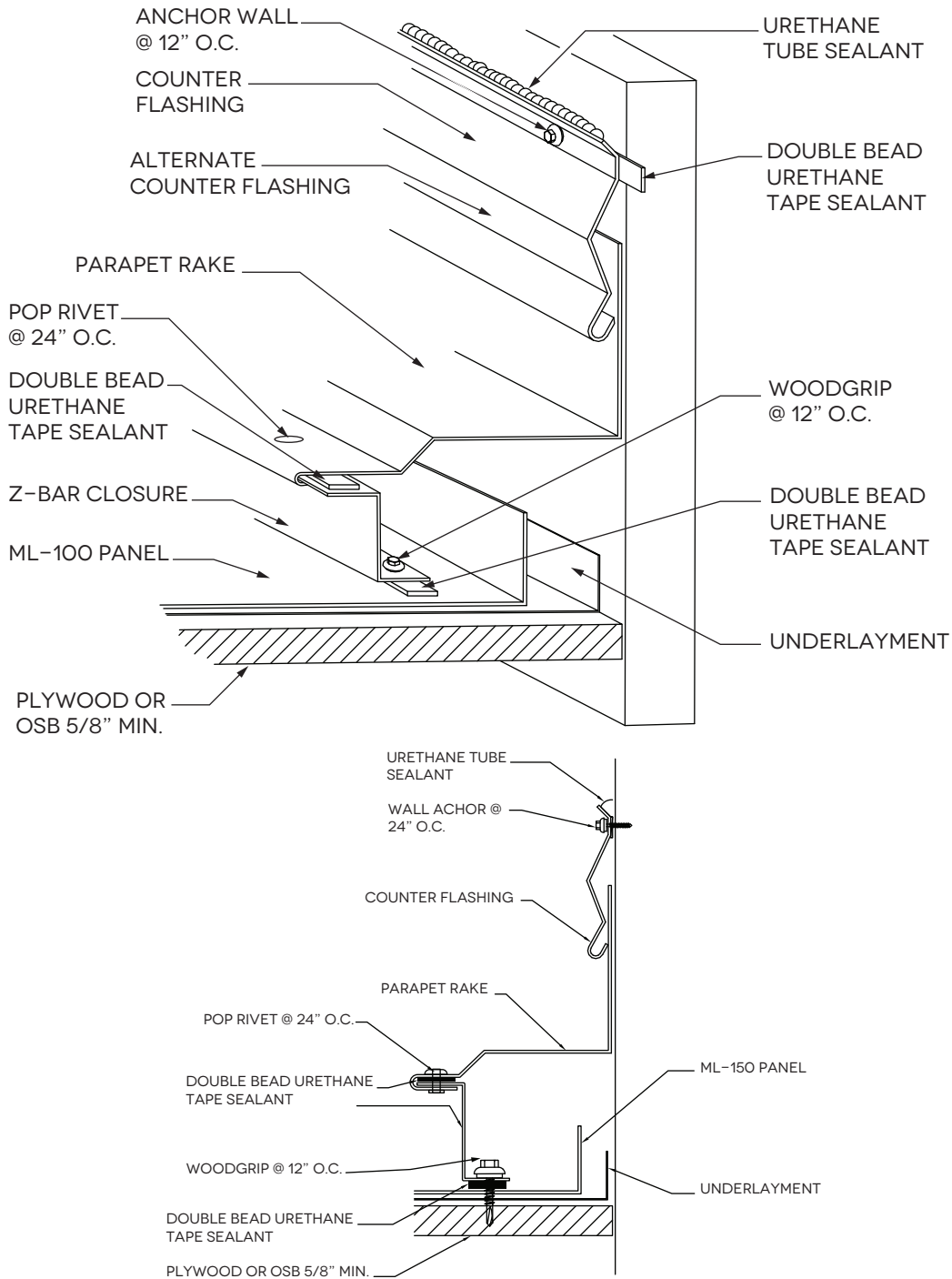

Installation

SIDEWALL WITH PARAPET RAKE AND REGLET FLASHING

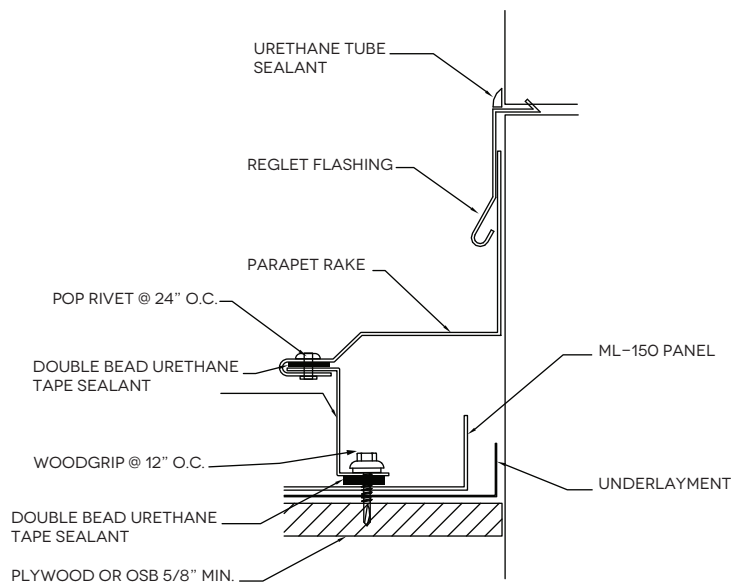
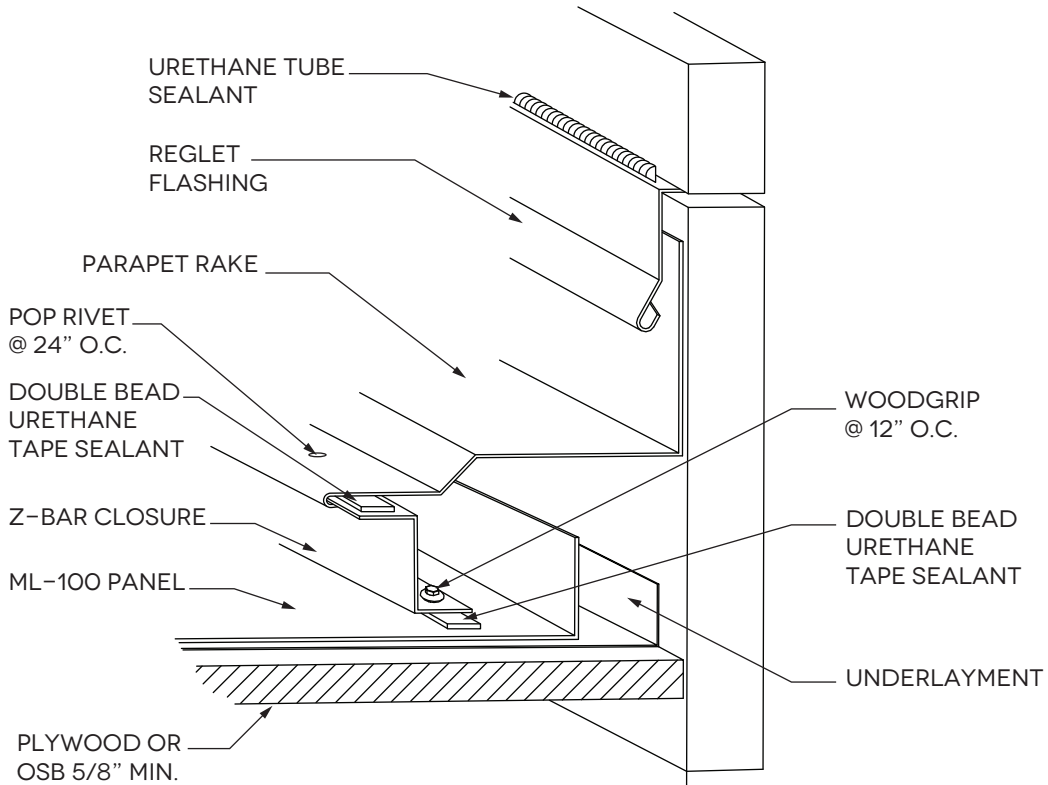

Installation

ML-150 OVER OPEN PURLIN

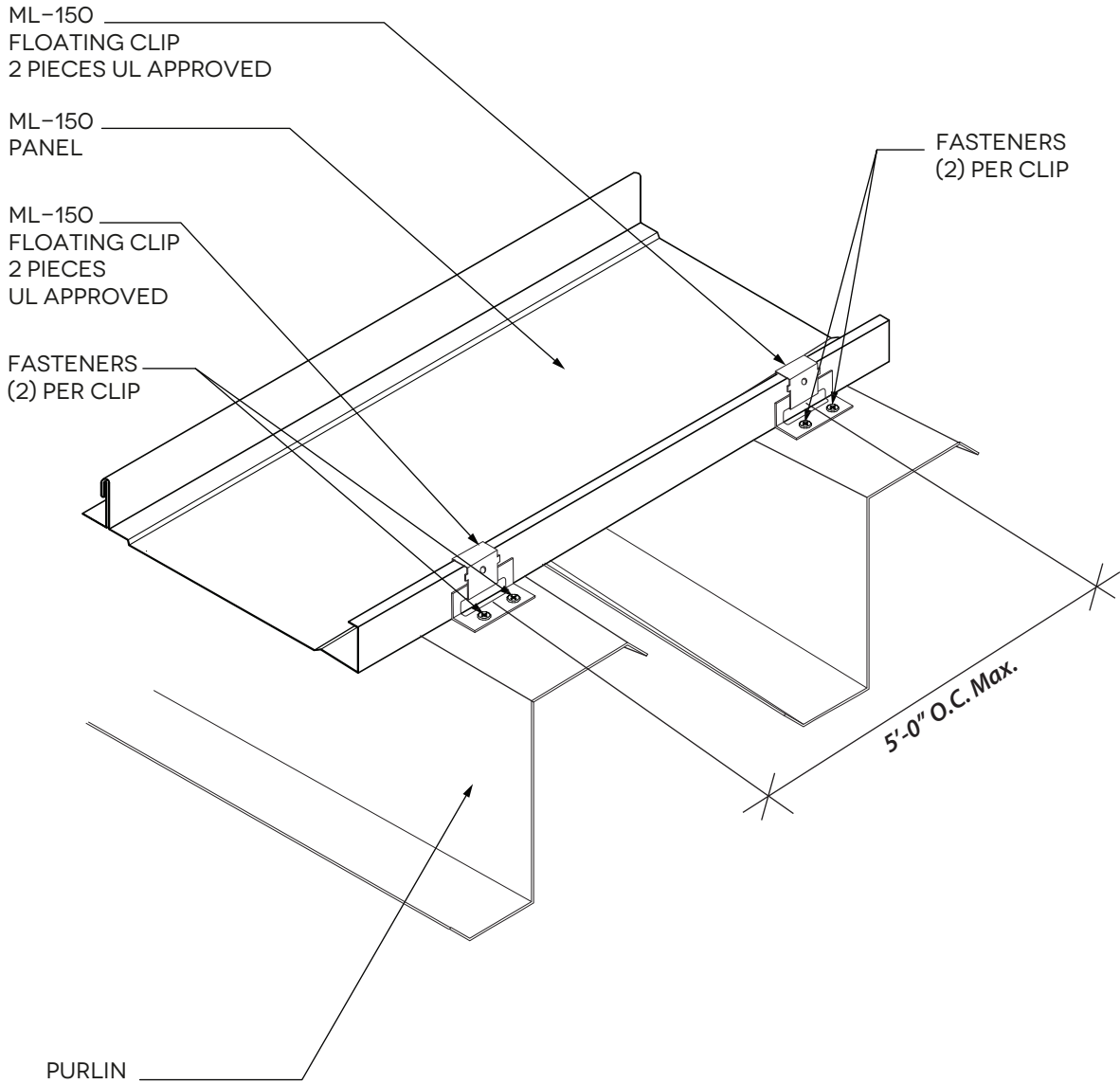

Installation

ML-150 OVER OPEN PURLIN WITH INSULATION

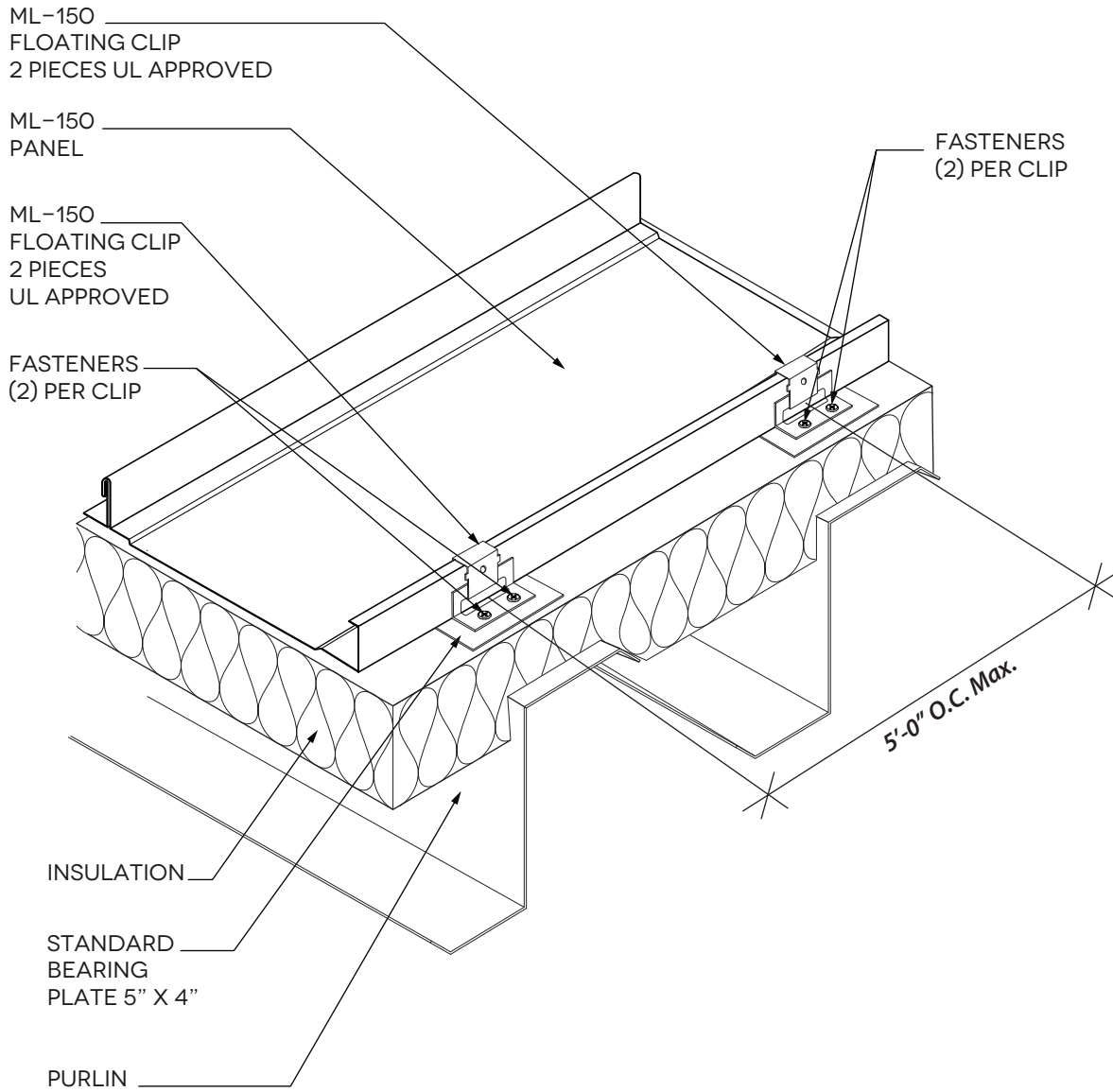

Installation

SCULPTURED RAKE OVER OPEN PURLIN

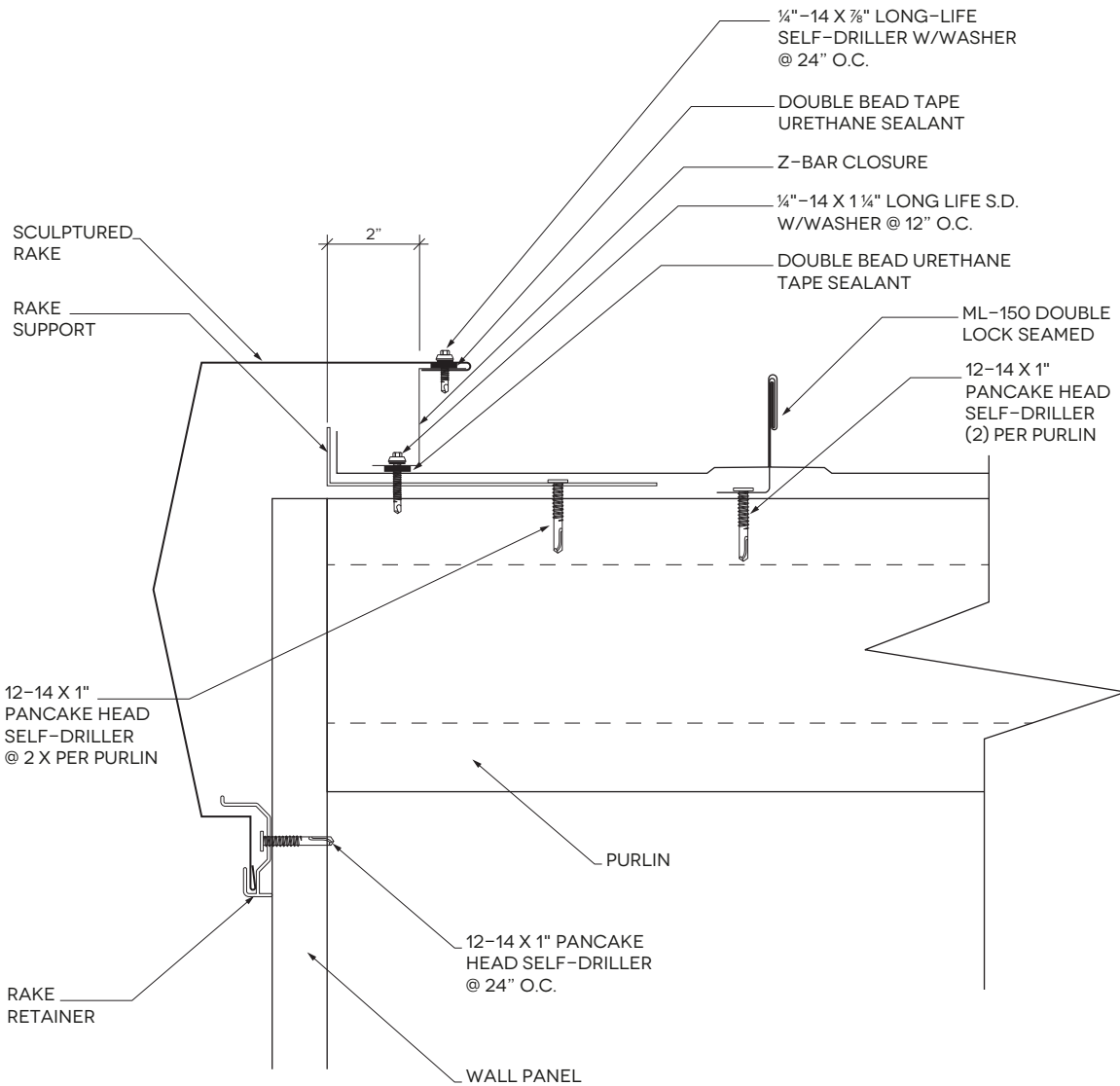

NOTE: CUT PANEL AT THE END OF THE SIDE WALL.

Installation

BOX RAKE OVER OPEN PURLIN

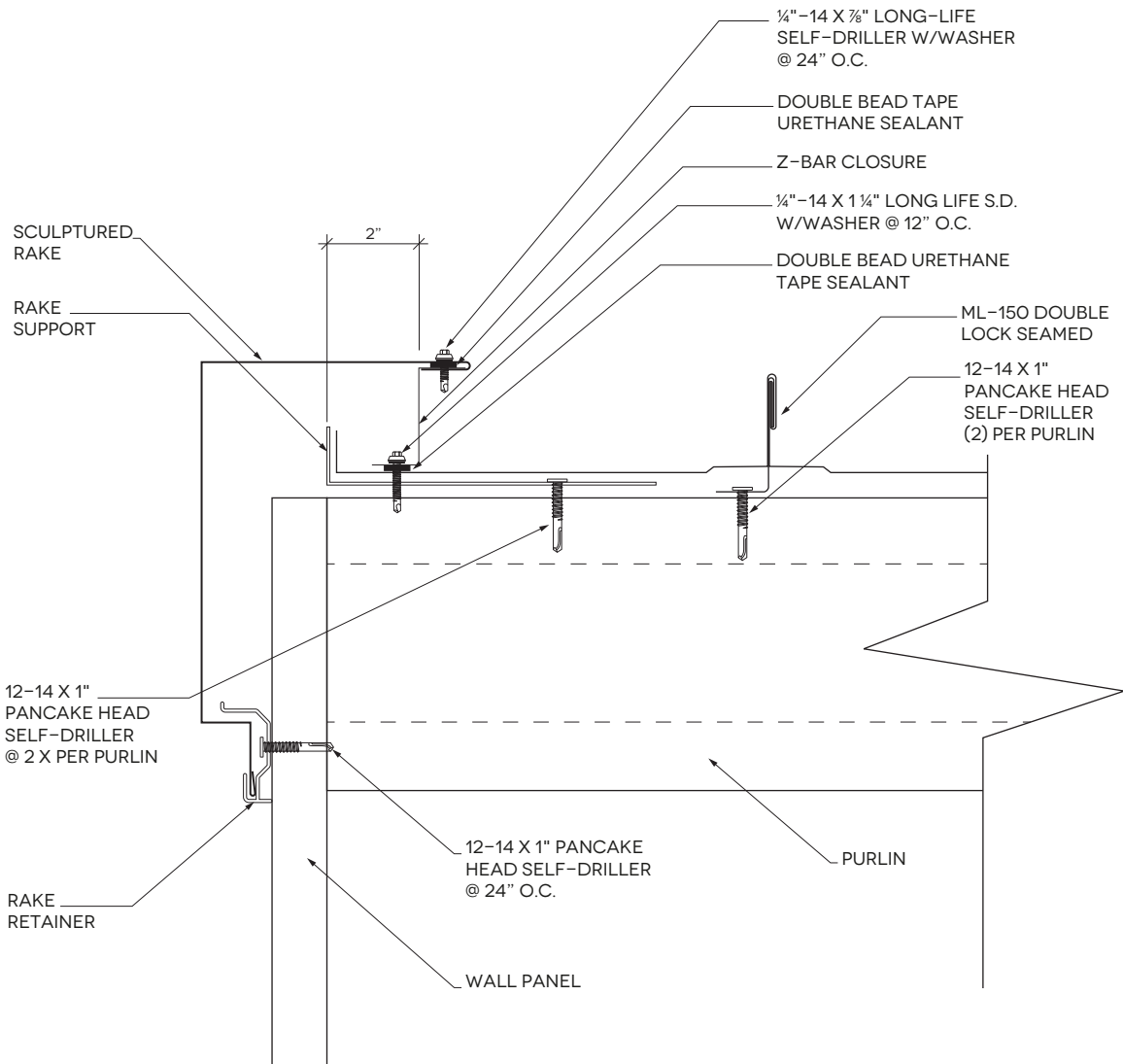

Installation

HIGH EAVE OVER OPEN PURLIN

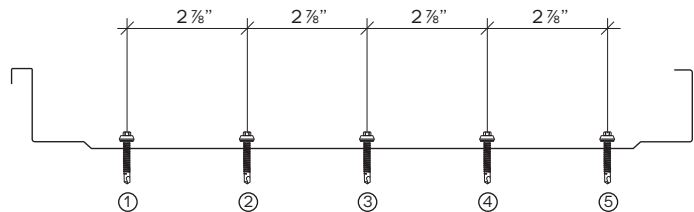
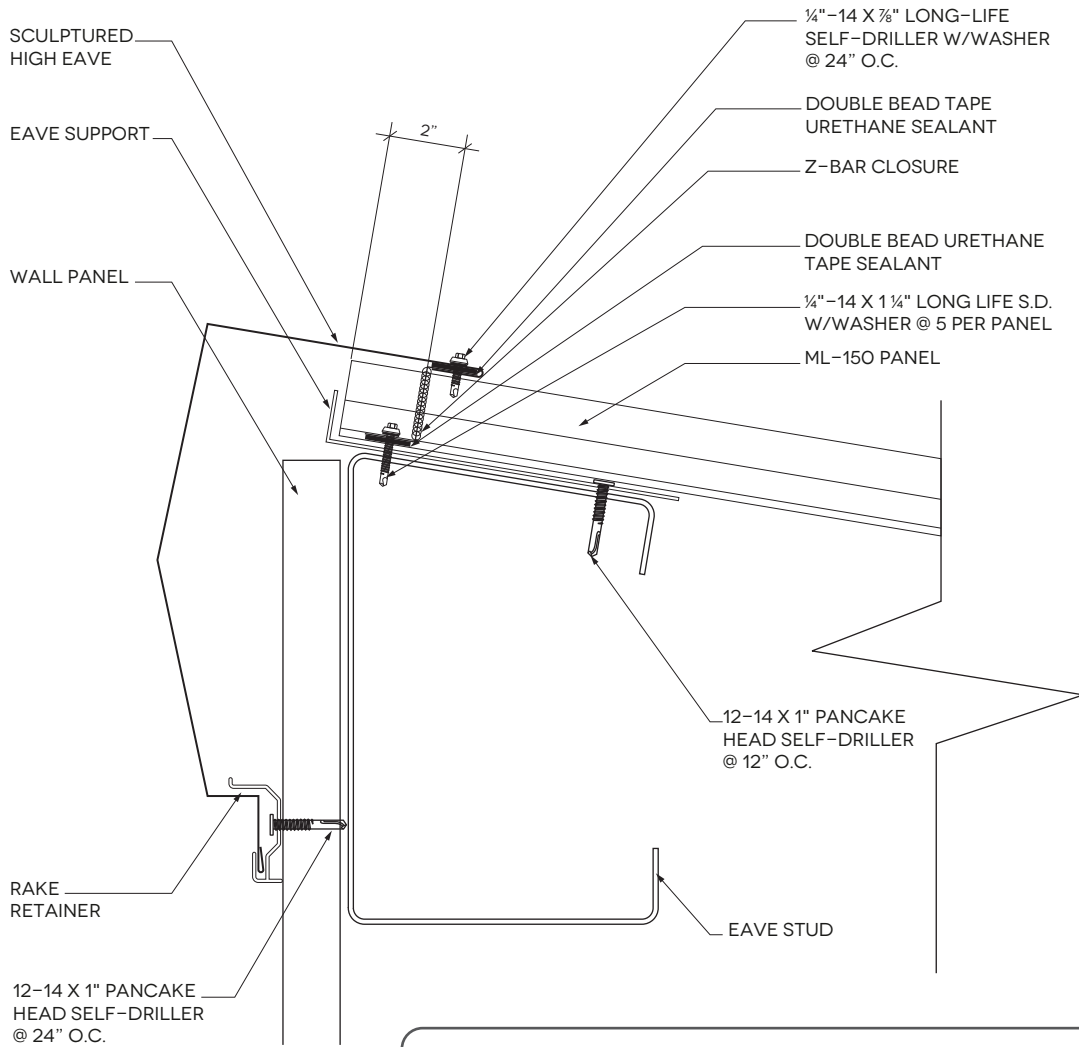

TYPICAL SCREW SEQUENCE AT EAVE

Installation

HIGH EAVE BOX OVER OPEN PURLIN

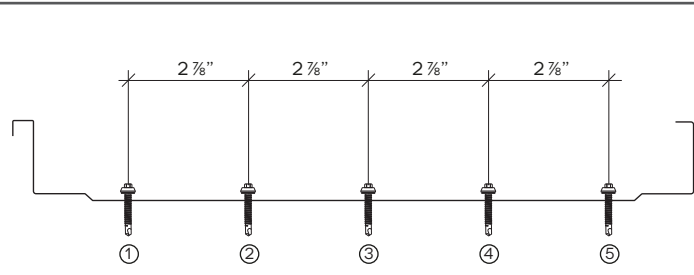
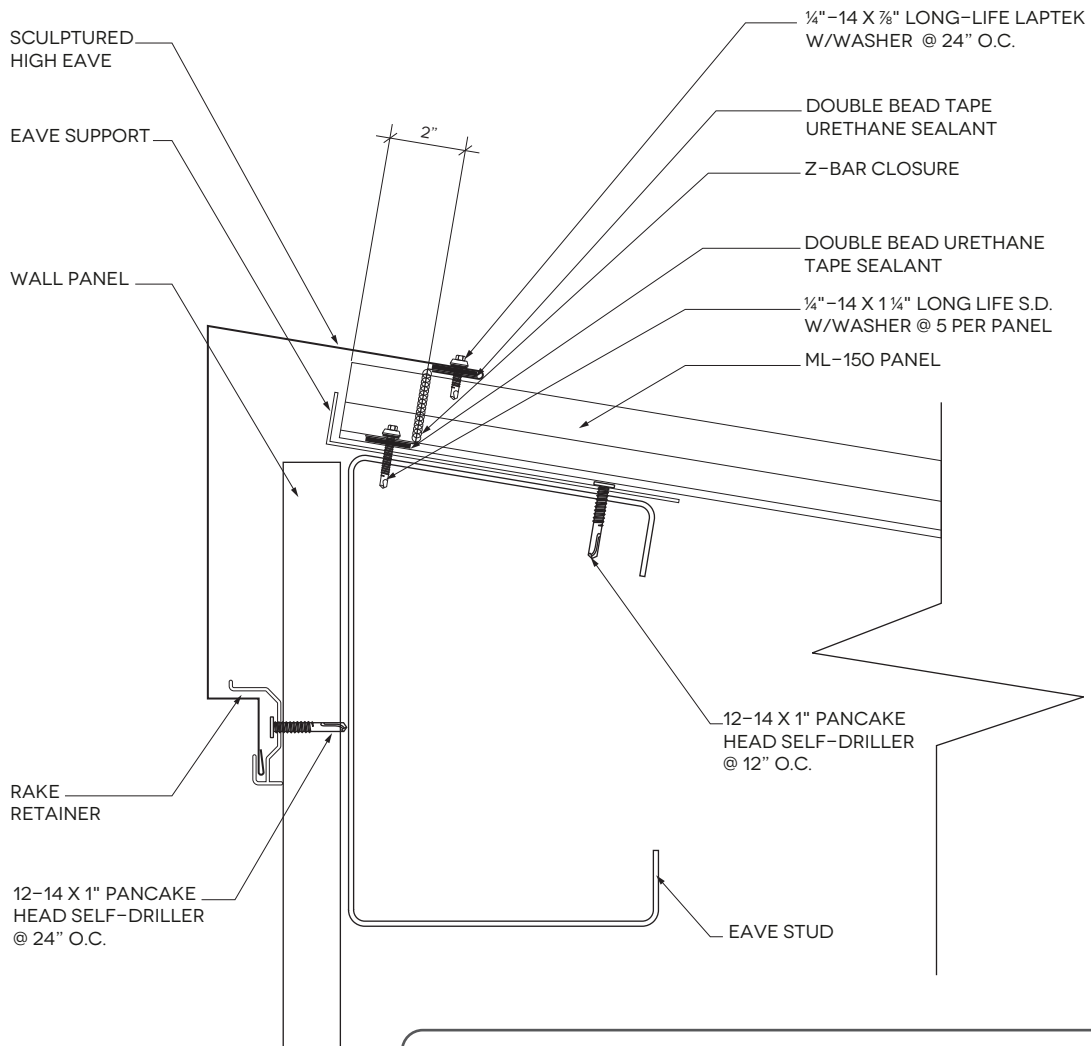

TYPICAL SCREW SEQUENCE AT EAVE

Installation

LOW EAVE OVER OPEN PURLIN

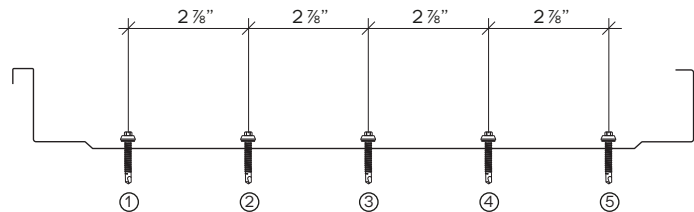
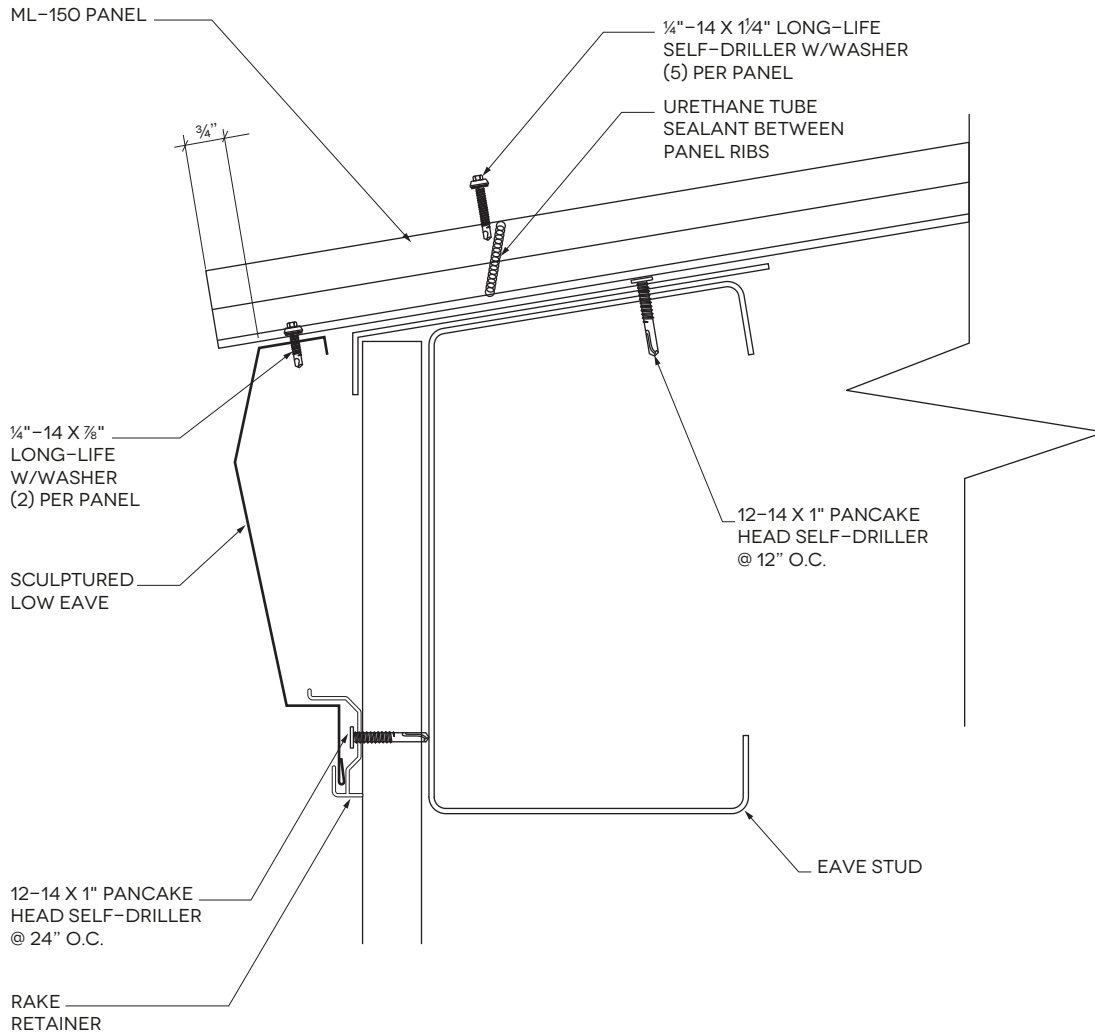

TYPICAL SCREW SEQUENCE AT EAVE

Quality Metals © ALL RIGHTS RESERVED 2023.

Installation

SCULPTURED GUTTER OVER OPEN PURLIN

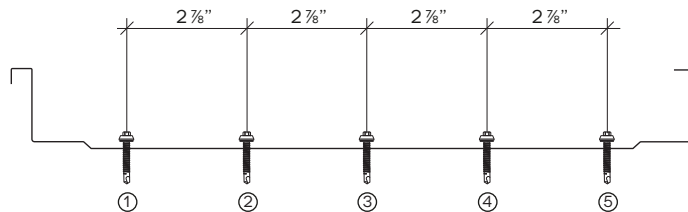
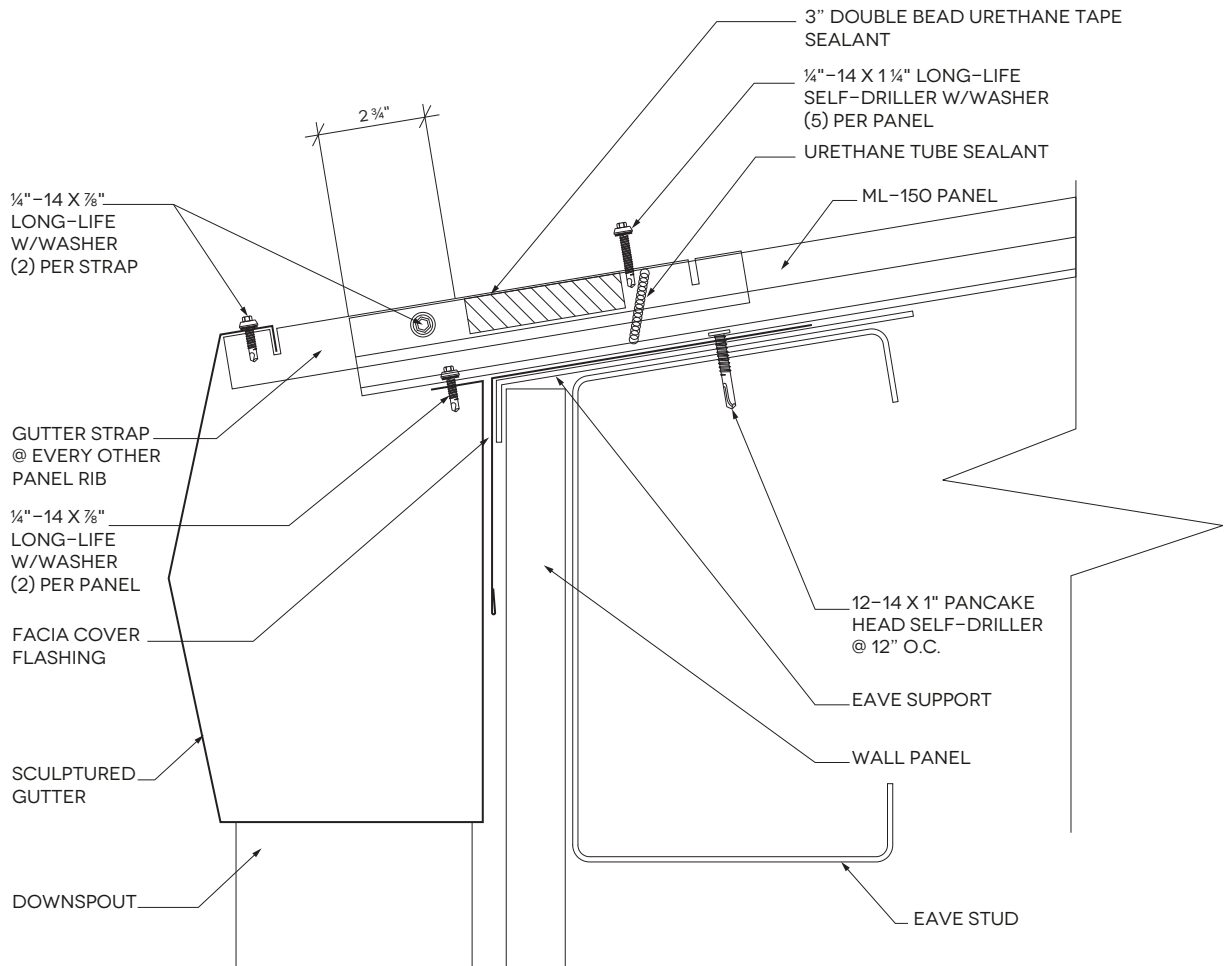

TYPICAL SCREW SEQUENCE AT EAVE

Installation

RIDGE CAP OVER OPEN PURLIN

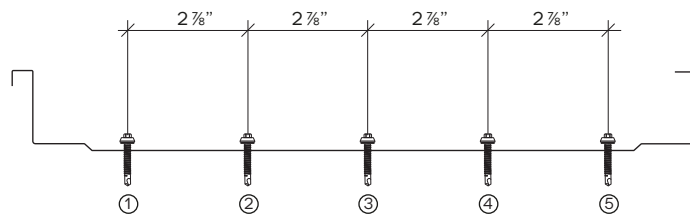
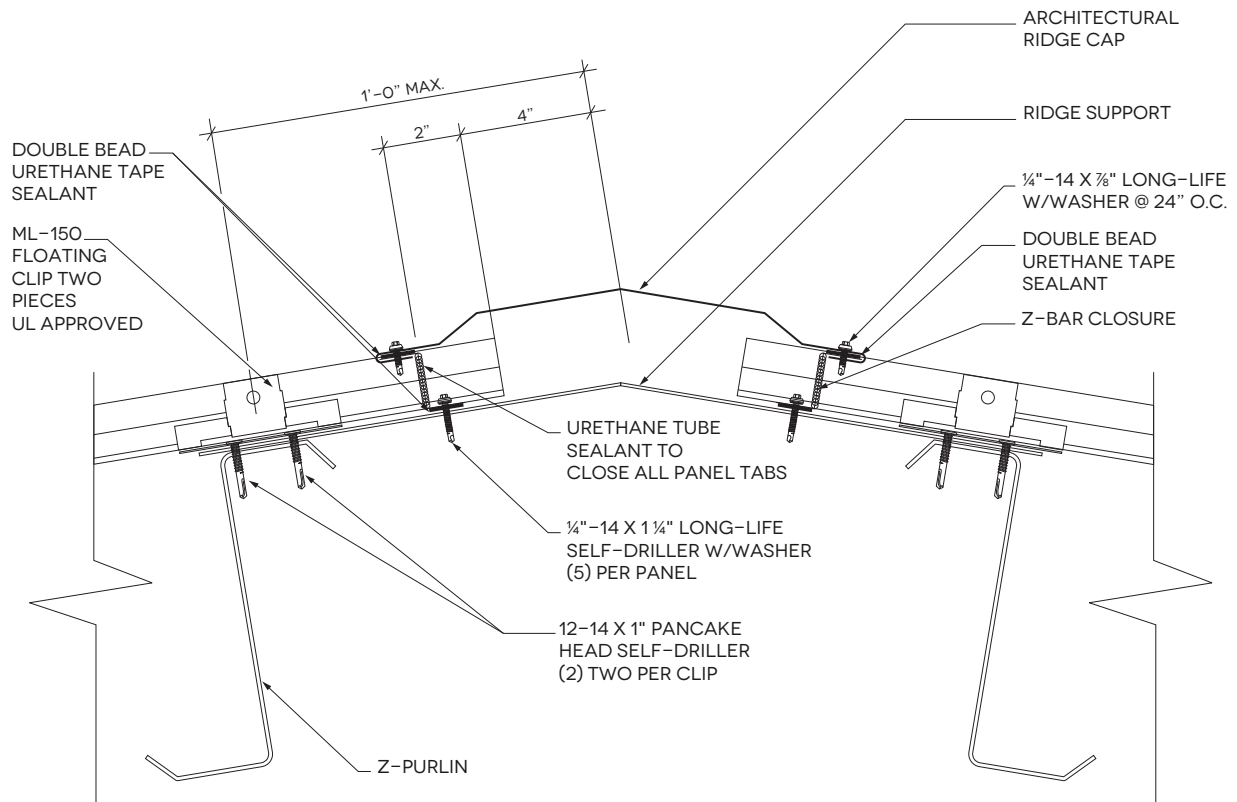

TYPICAL SCREW SEQUENCE AT HIGH EAVE

Installation

PARAPET RAKE OVER OPEN PURLIN AT HIGH EAVE WALL

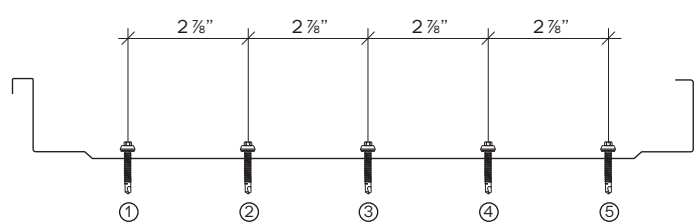
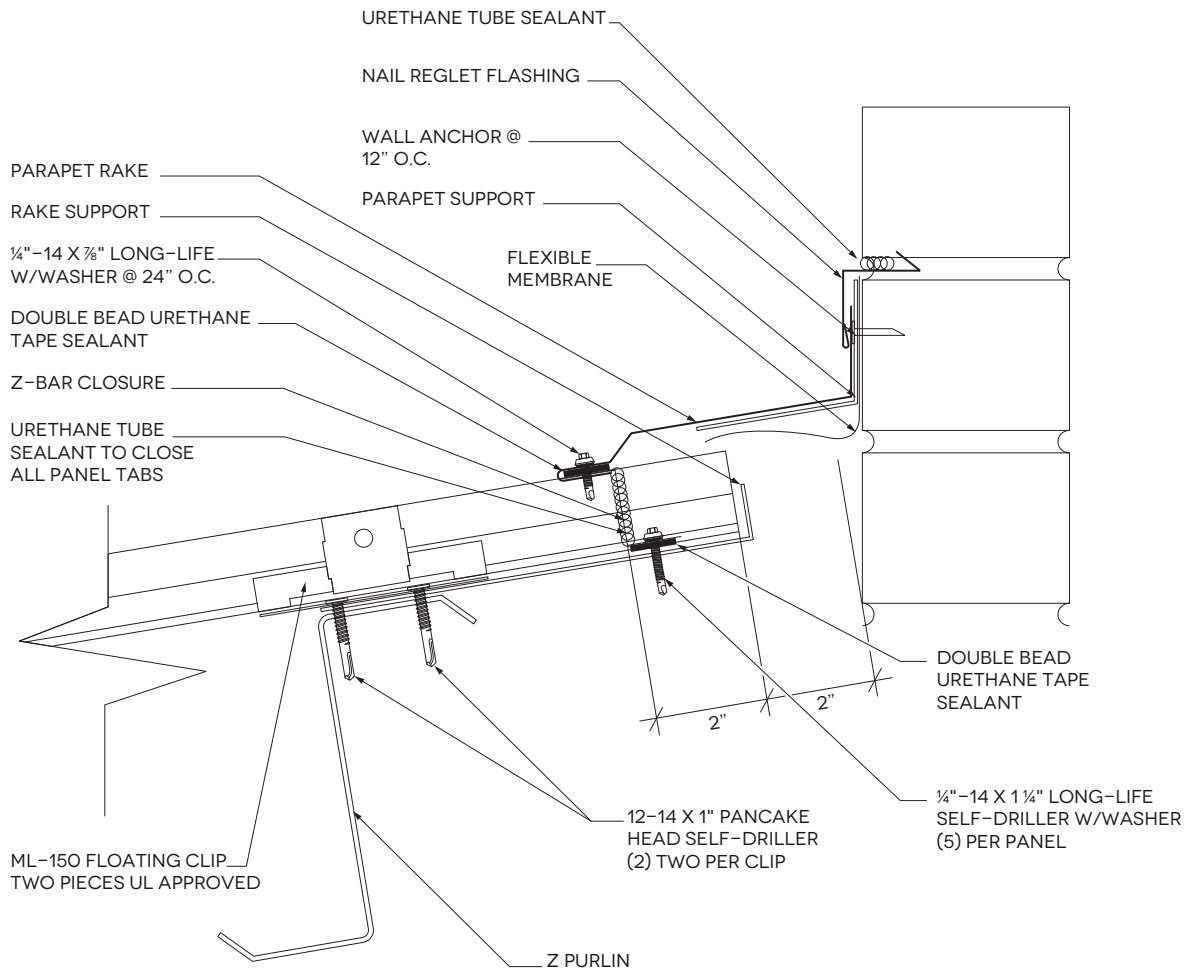

TYPICAL SCREW SEQUENCE AT HIGH EAVE

Installation

PARAPET RAKE OVER OPEN PURLIN AT SIDE WALL

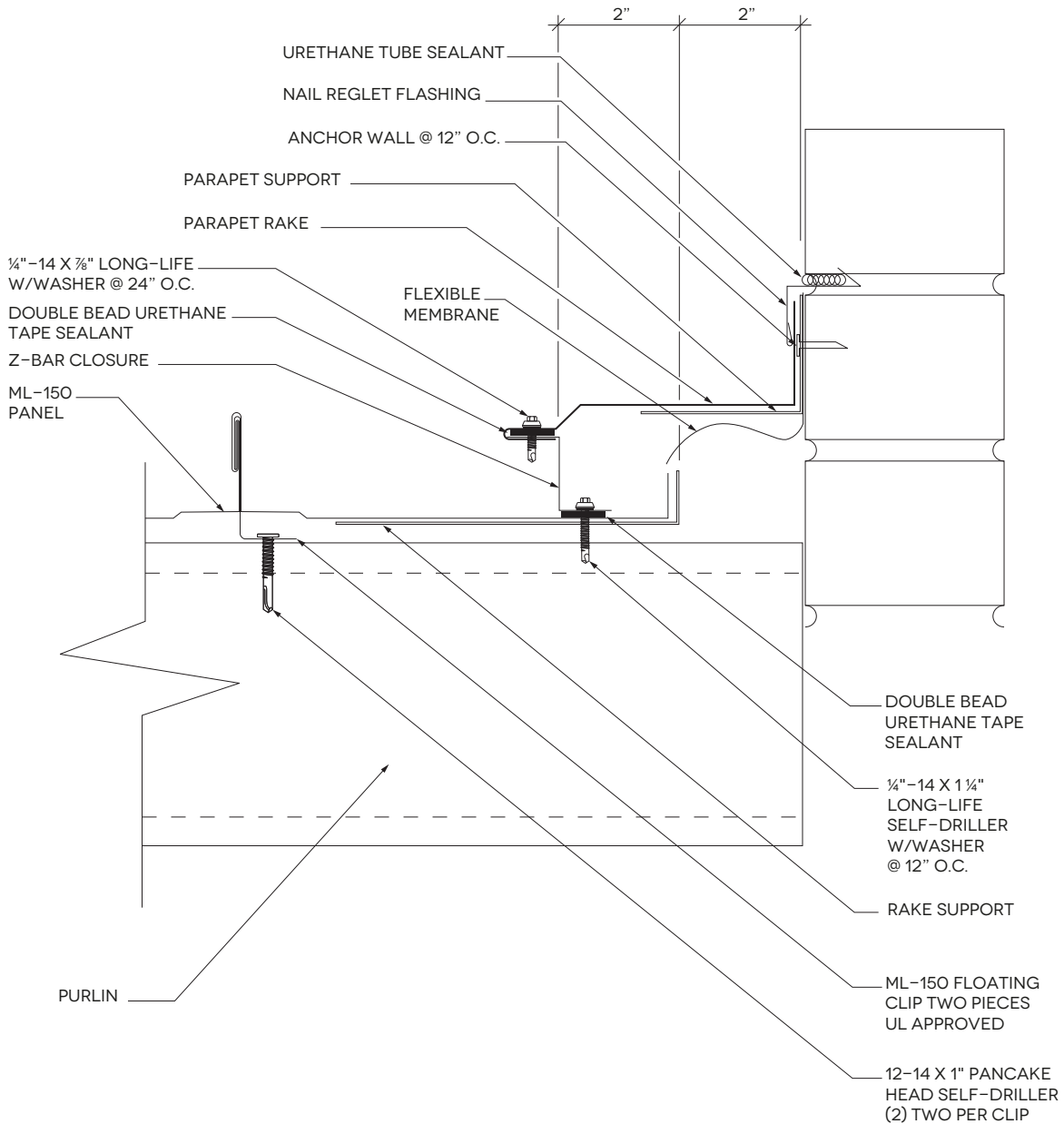

Installation

PEAK VALLEY OPEN PURLIN

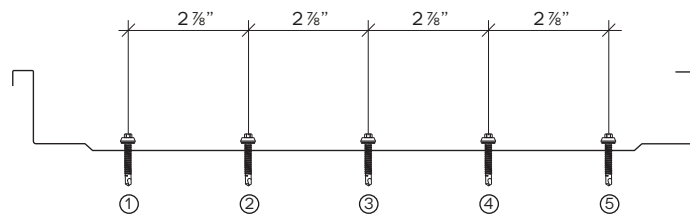
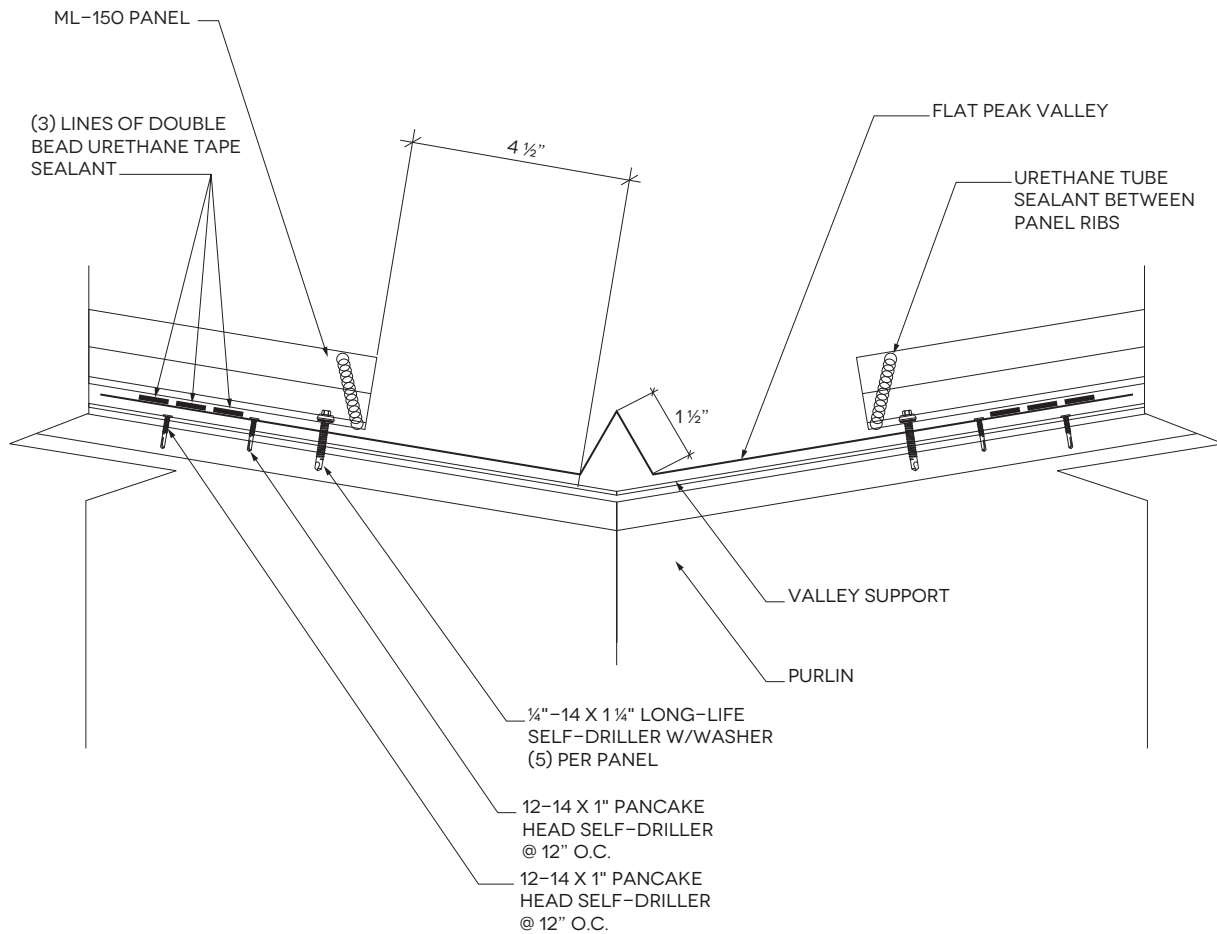

TYPICAL SCREW SEQUENCE AT VALLEY

Installation

ML-150 OVER METAL DECKING WITH RIGID INSULATION

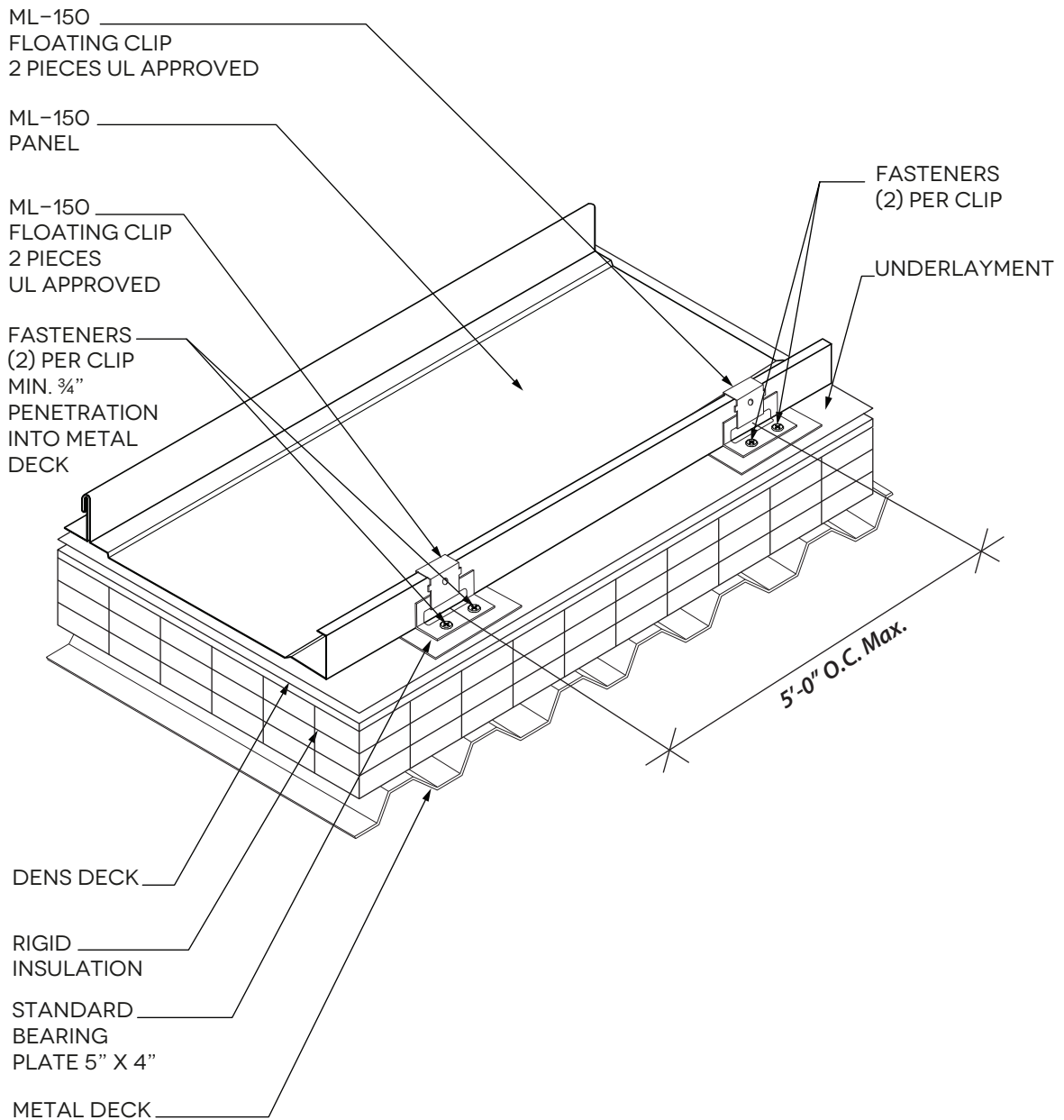

Installation

DRIP EDGE AT RAKE OVER METAL DECK WITH RIGID INSULATION

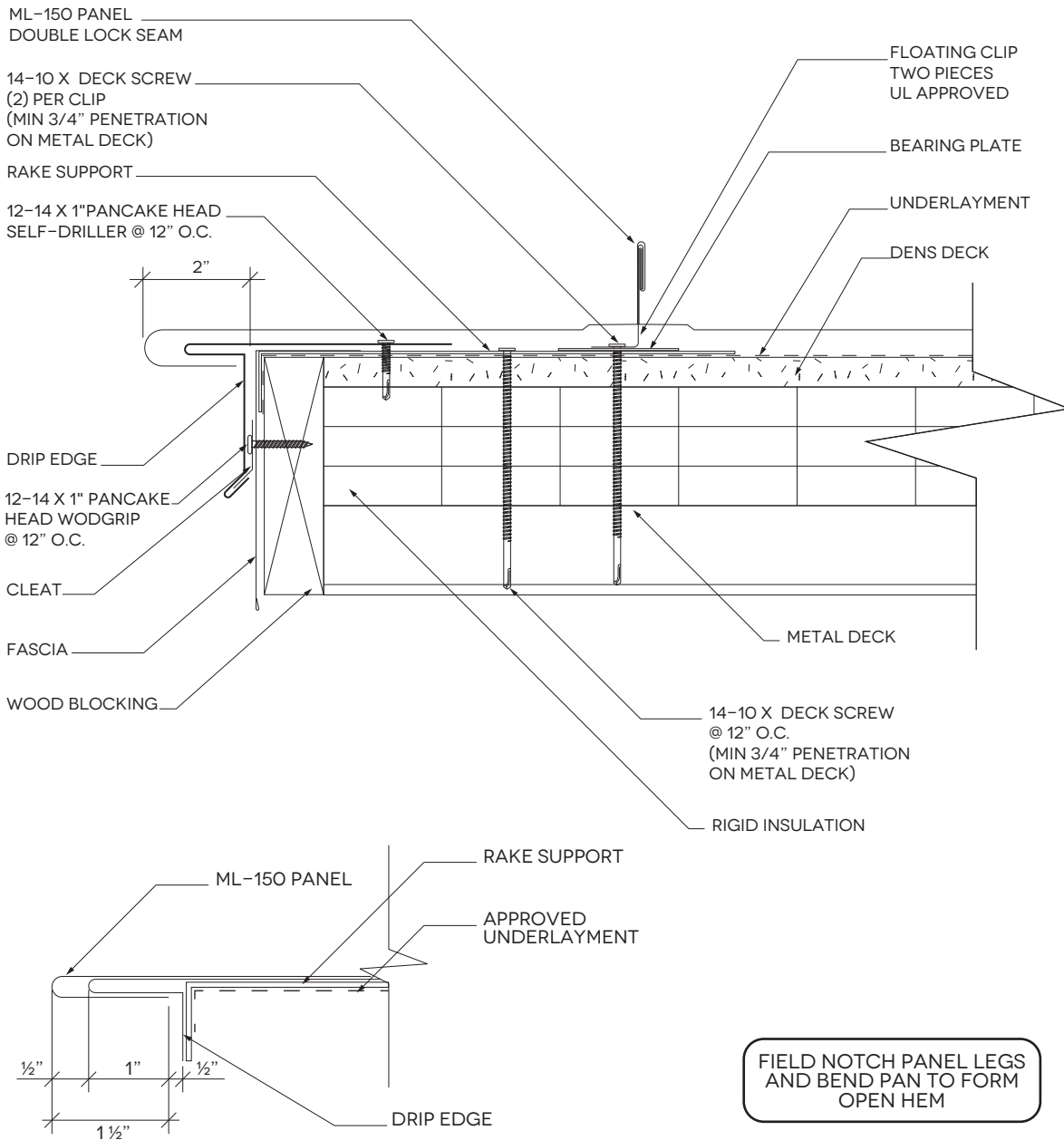

Installation

SCULPTURED RAKE OVER METAL DECK WITH RIGID INSULATION

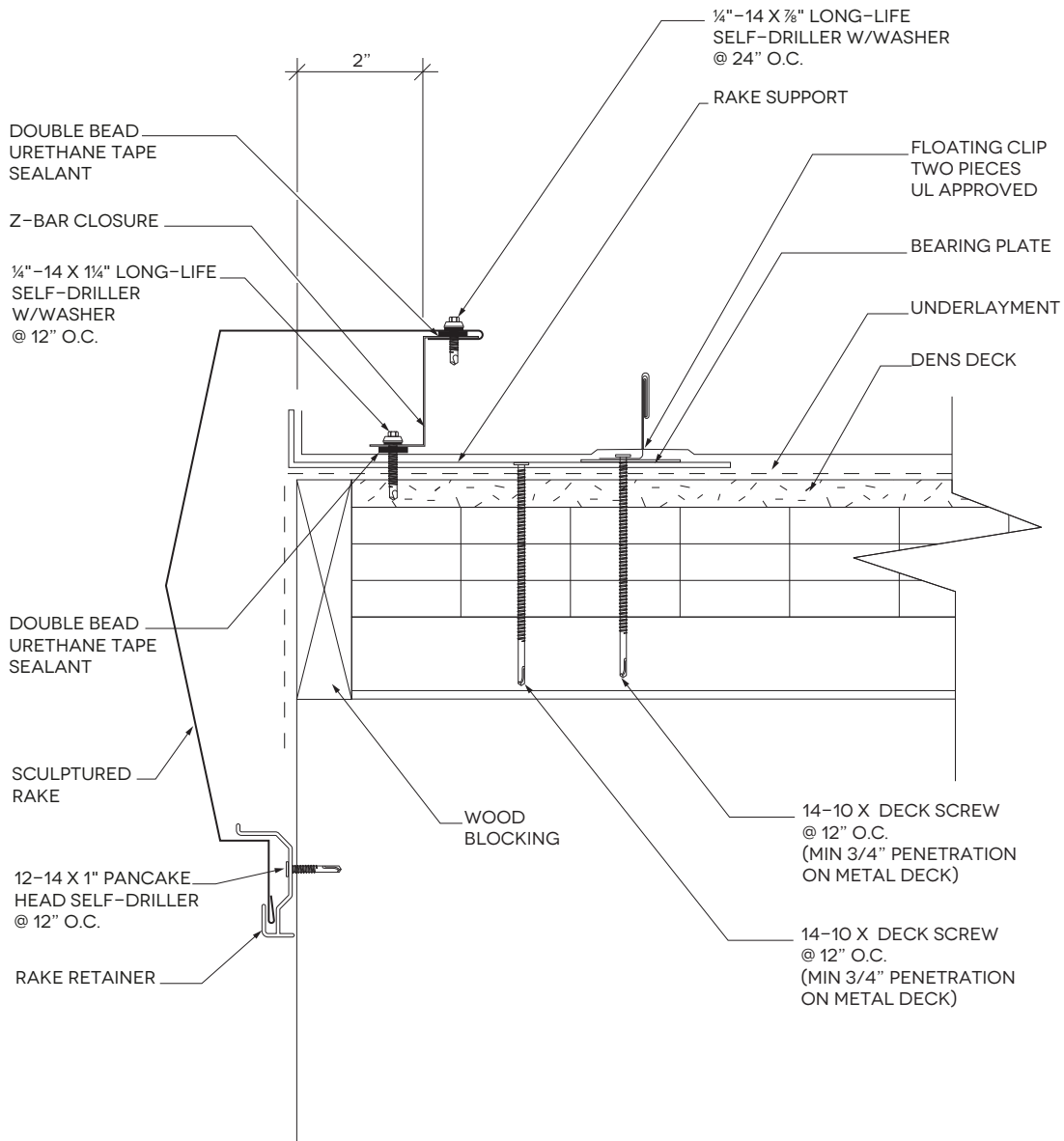

Installation

BOX RAKE OVER METAL DECK WITH RIGID INSULATION

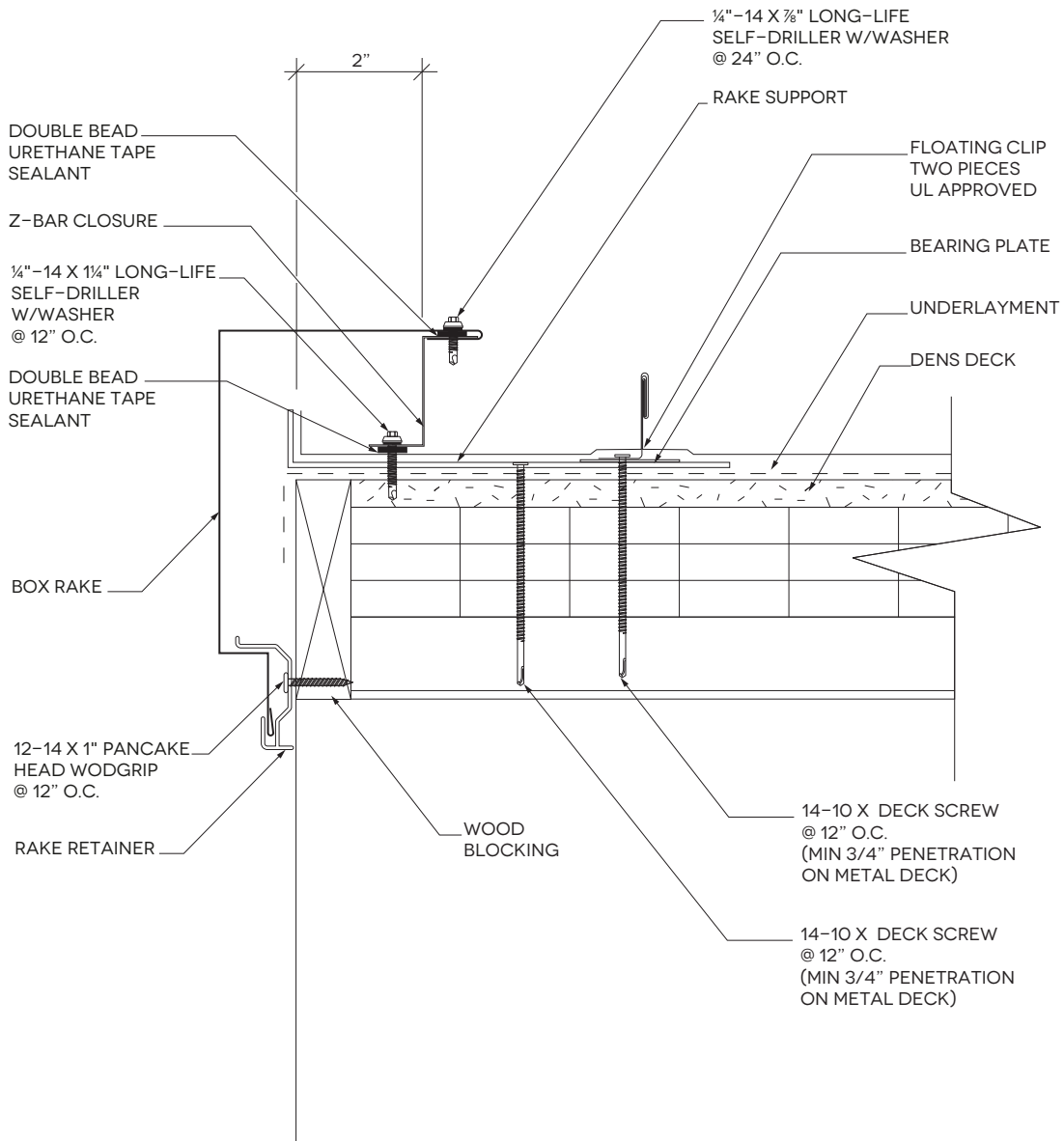

Installation

DRIP EDGE AT HIGH EAVE OVER METAL DECK WITH RIGID INSULATION

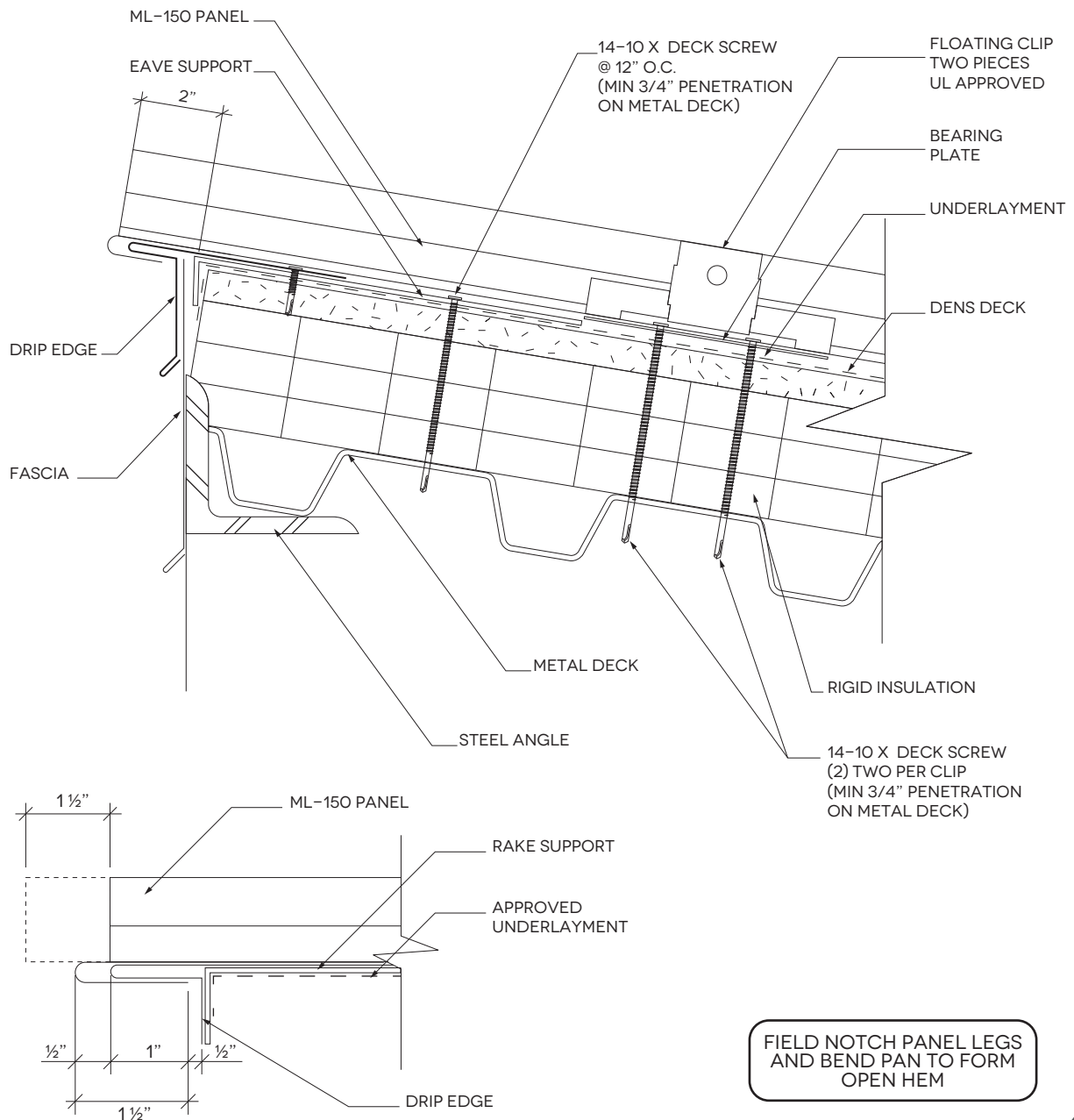

Installation

SCULPTURED EAVE OVER METAL DECK WITH RIGID INSULATION

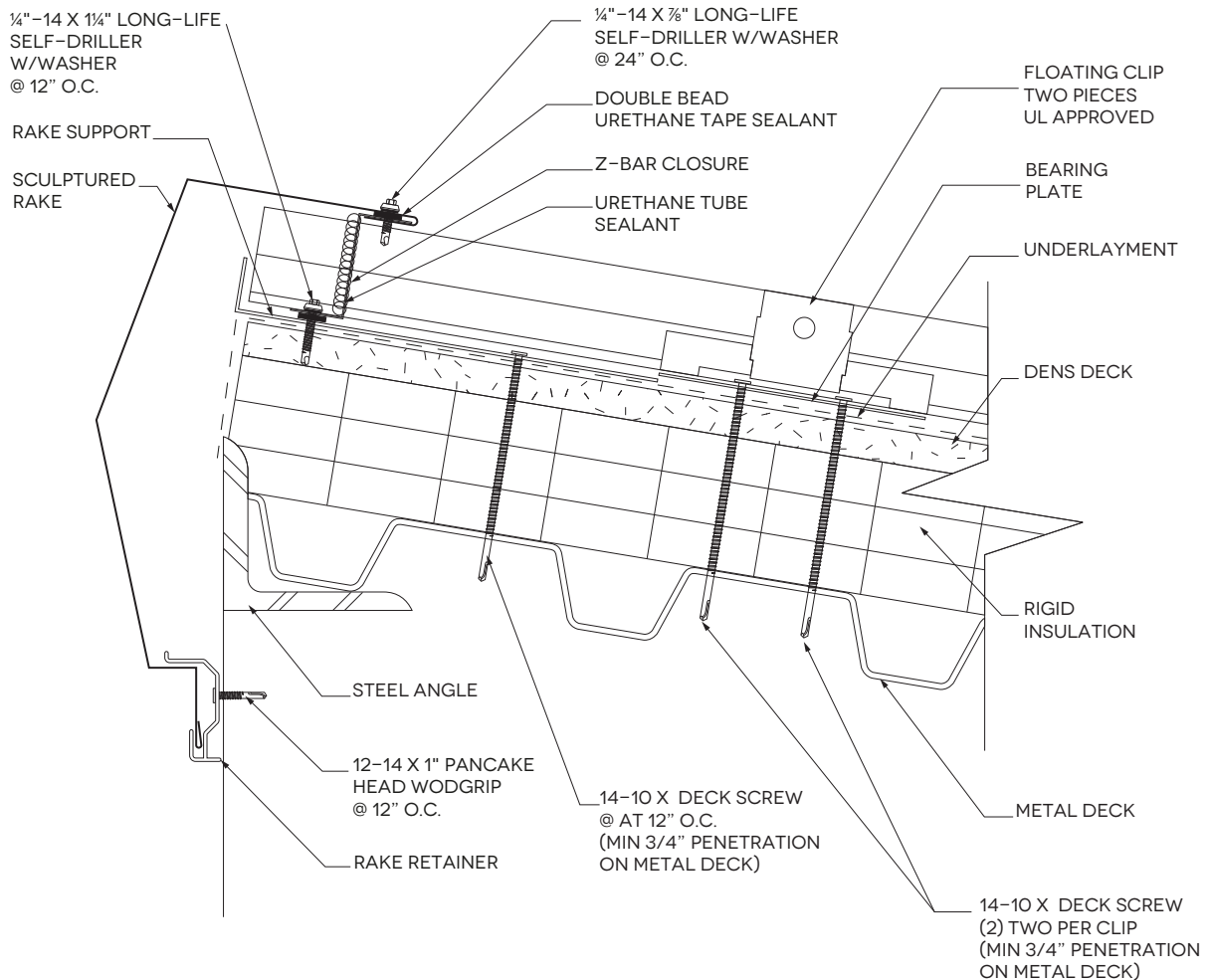

Installation

BOX EAVE OVER METAL DECK WITH RIGID INSULATION

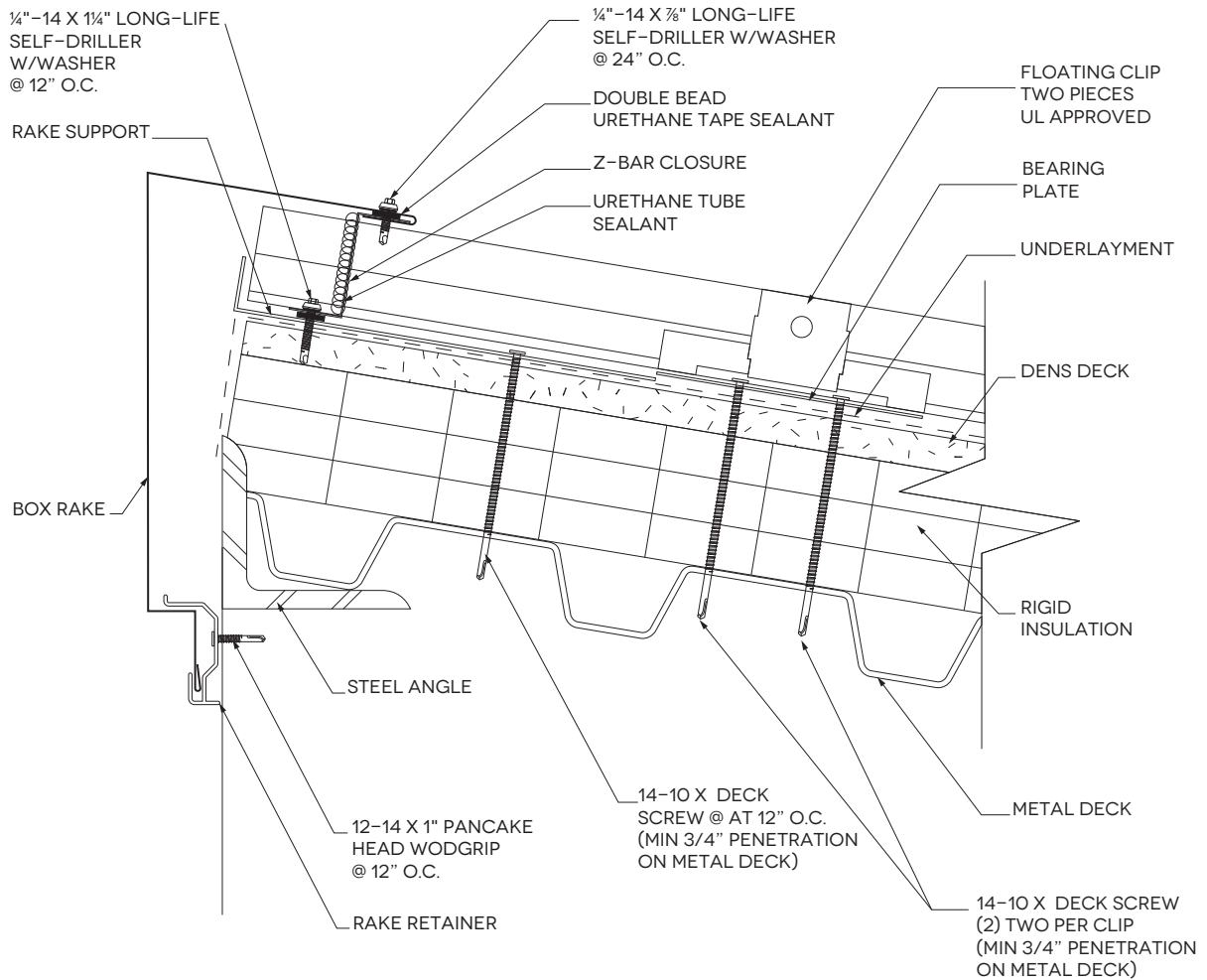

Installation

SCULPTURED GUTTER OVER METAL DECK WITH RIGID INSULATION

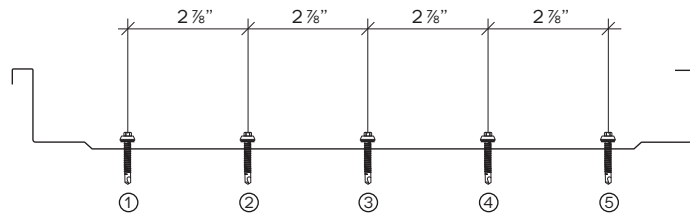
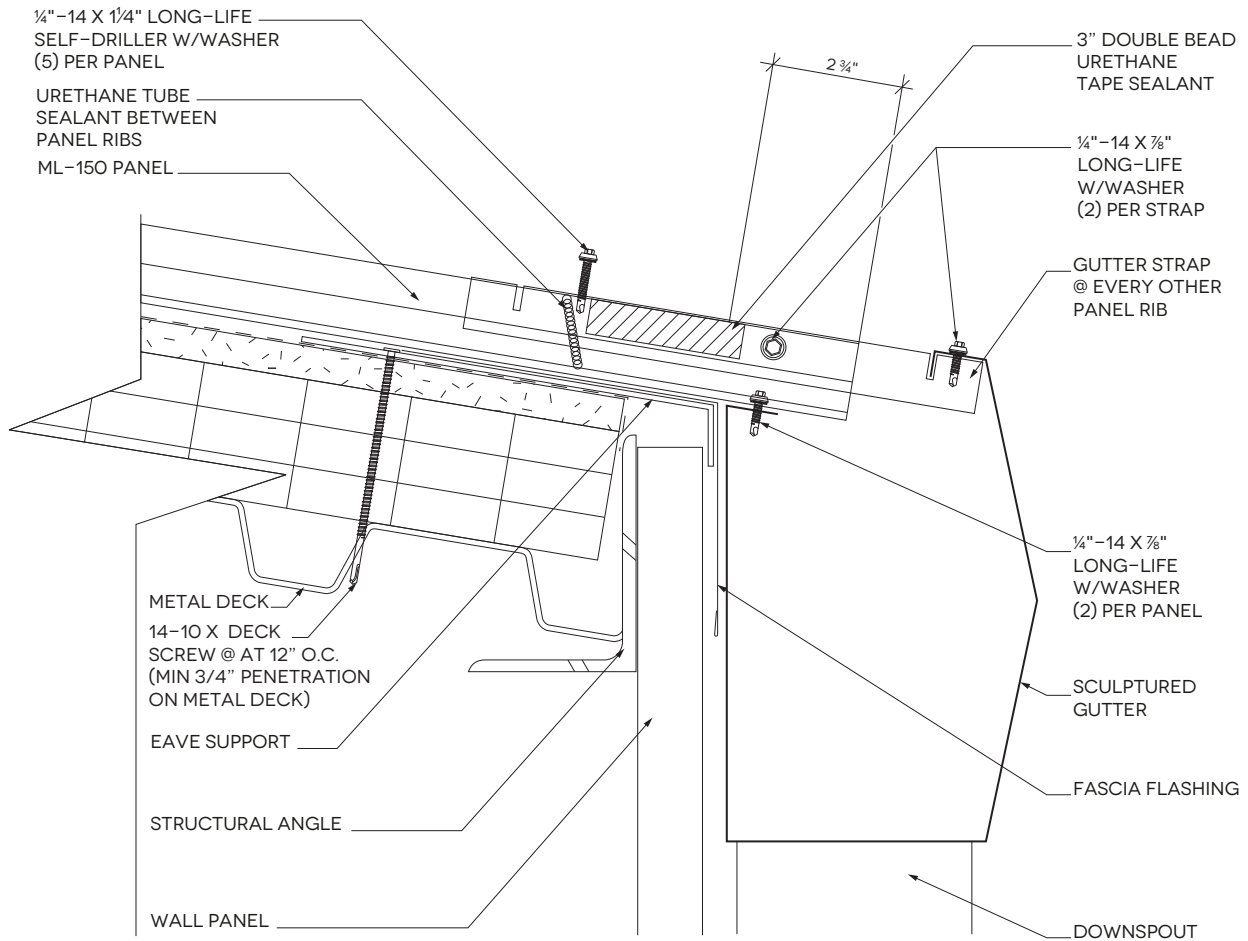

TYPICAL SCREW SEQUENCE AT LOW EAVE

Installation

GUTTER WITH DRIP EDGE INTEGRATED OVER METAL DECK WITH RIGID INSULATION

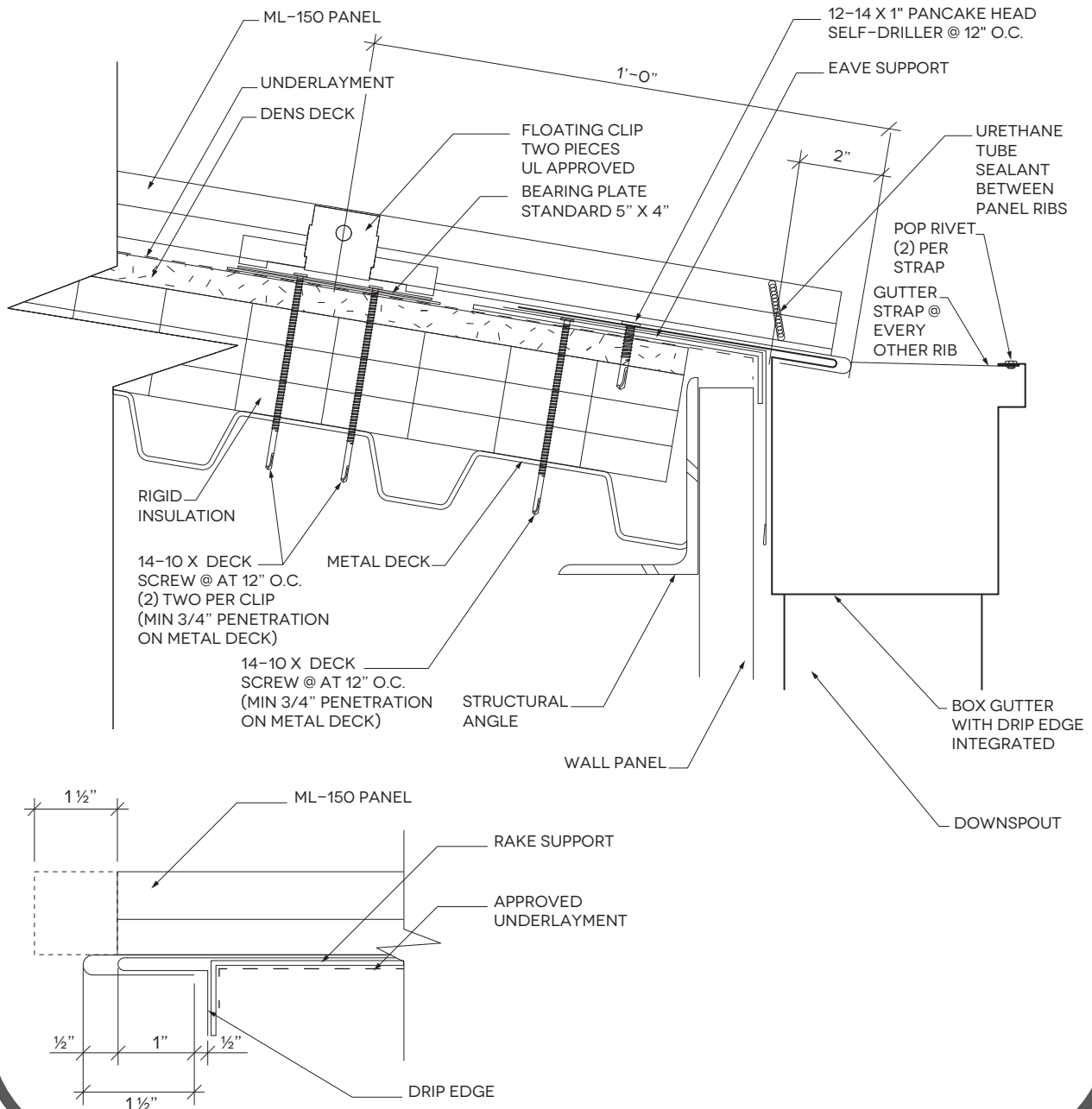

Installation

RIDGE CAP OVER METAL DECK WITH RIGID INSULATION

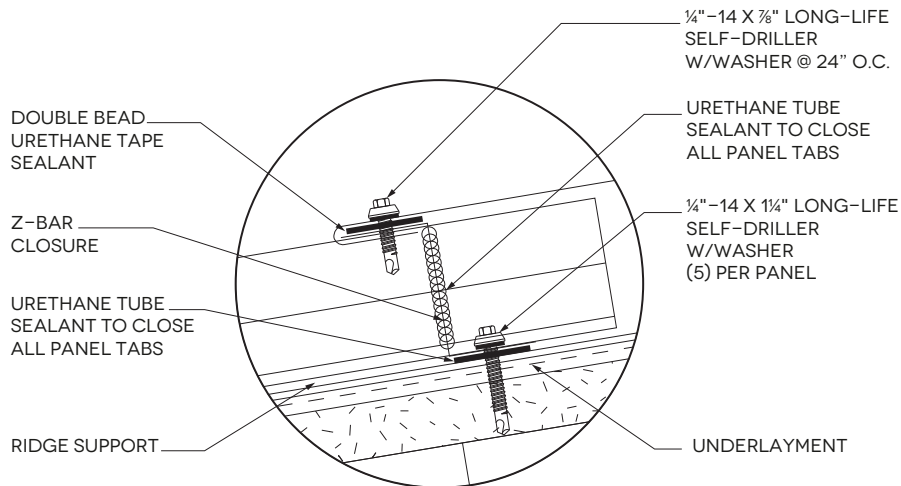
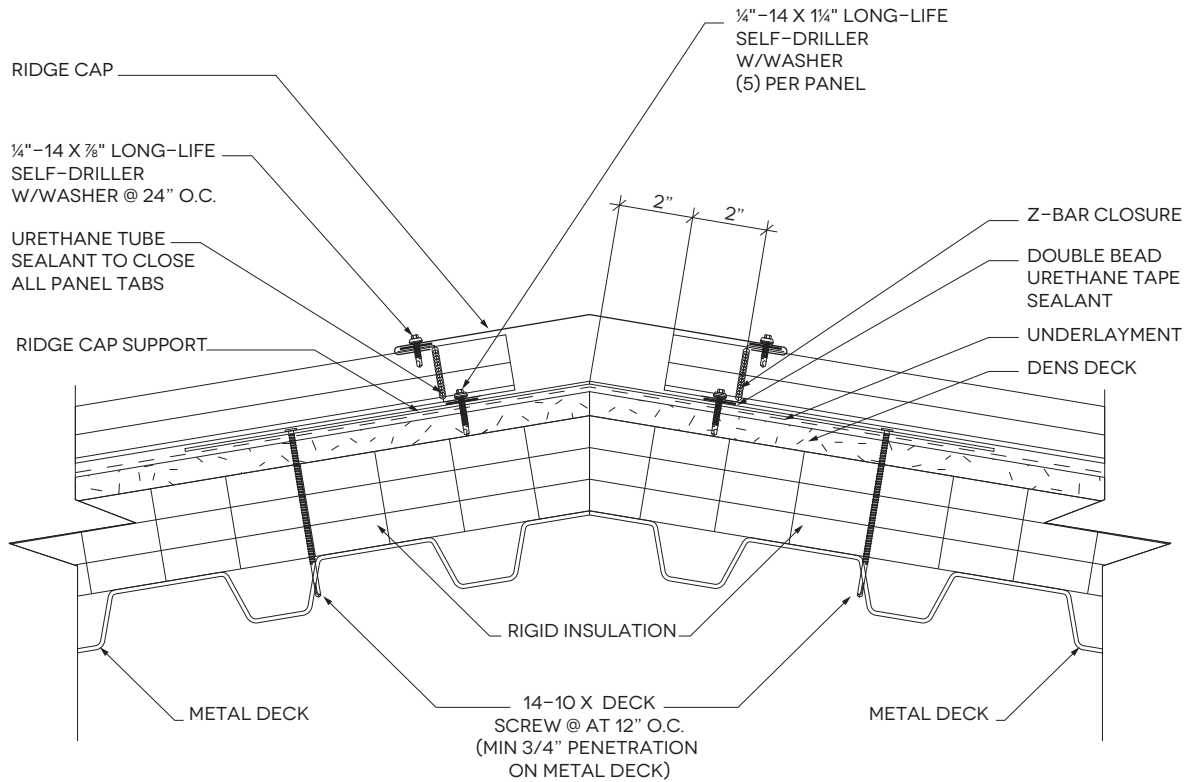

Installation

PARAPET RAKE OVER OPEN PURLIN AT HIGH EAVE WALL

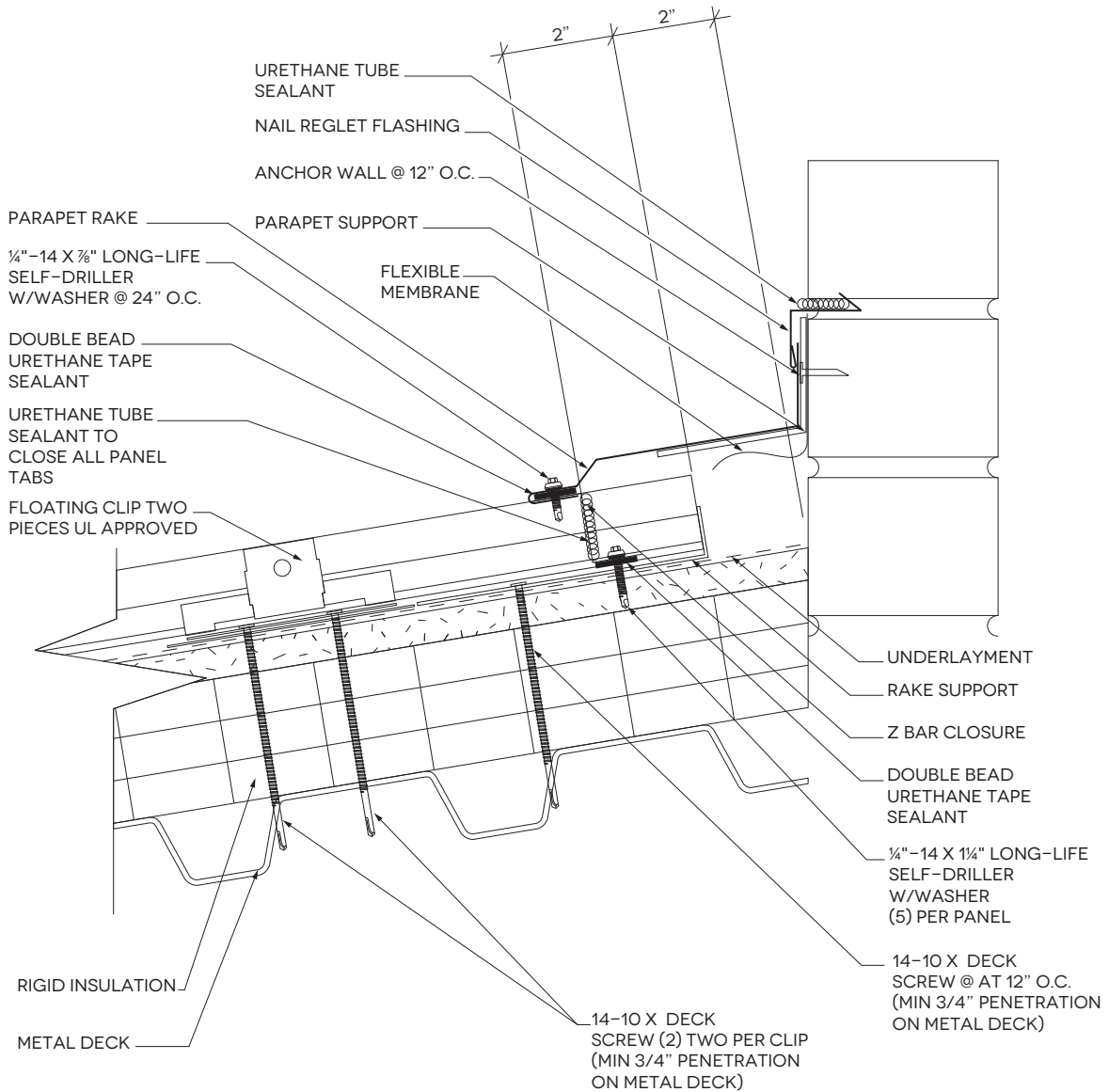

Installation

PARAPET RAKE OVER OPEN PURLIN AT SIDE WALL

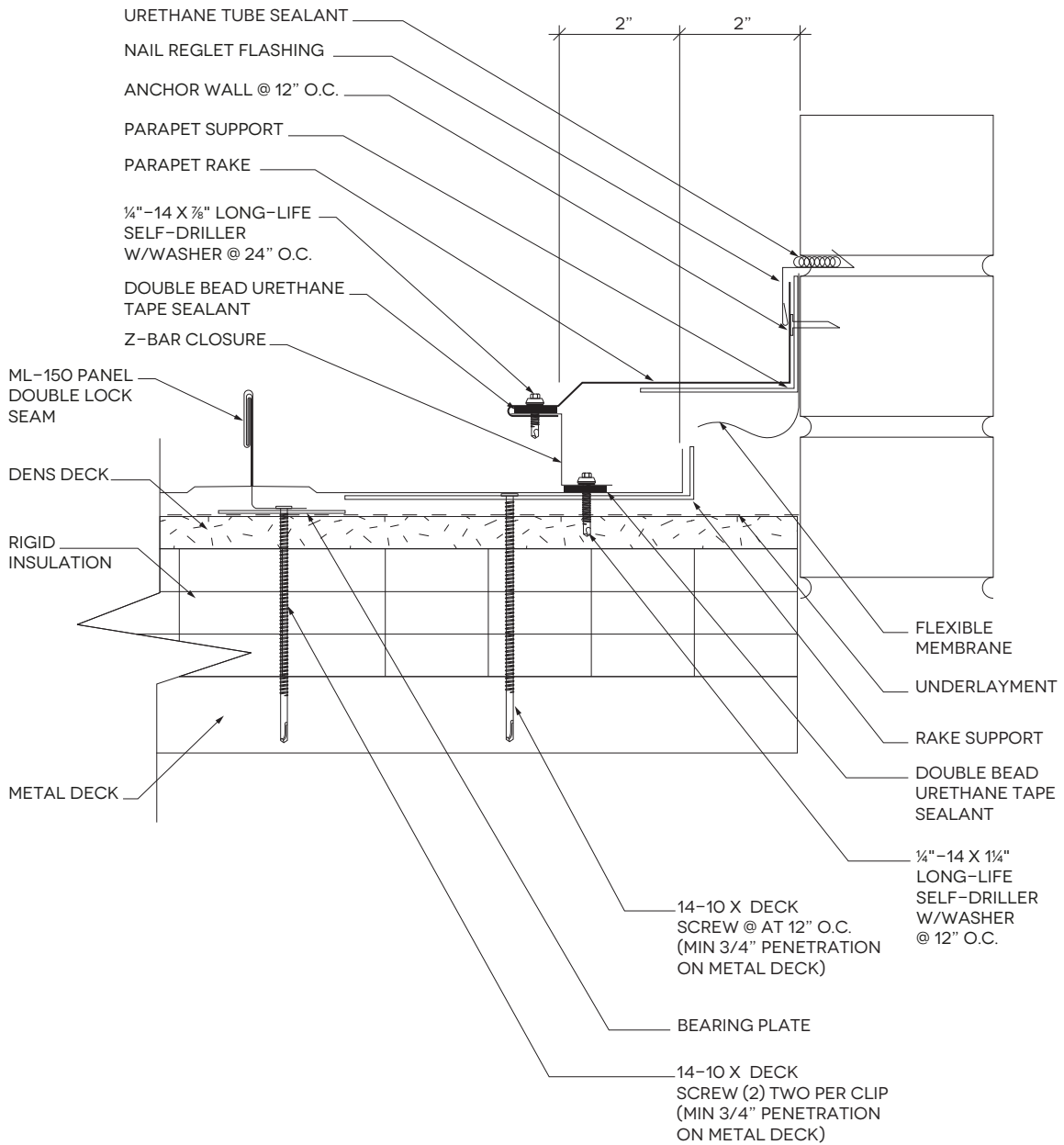

Installation

PEAK VALLEY OVER METAL DECK WITH RIGID INSULATION

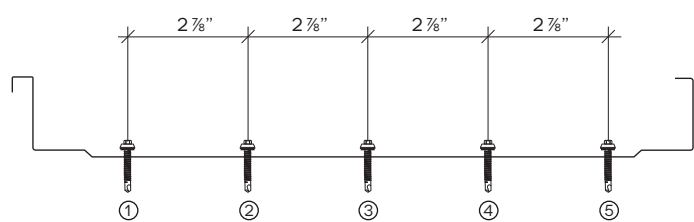
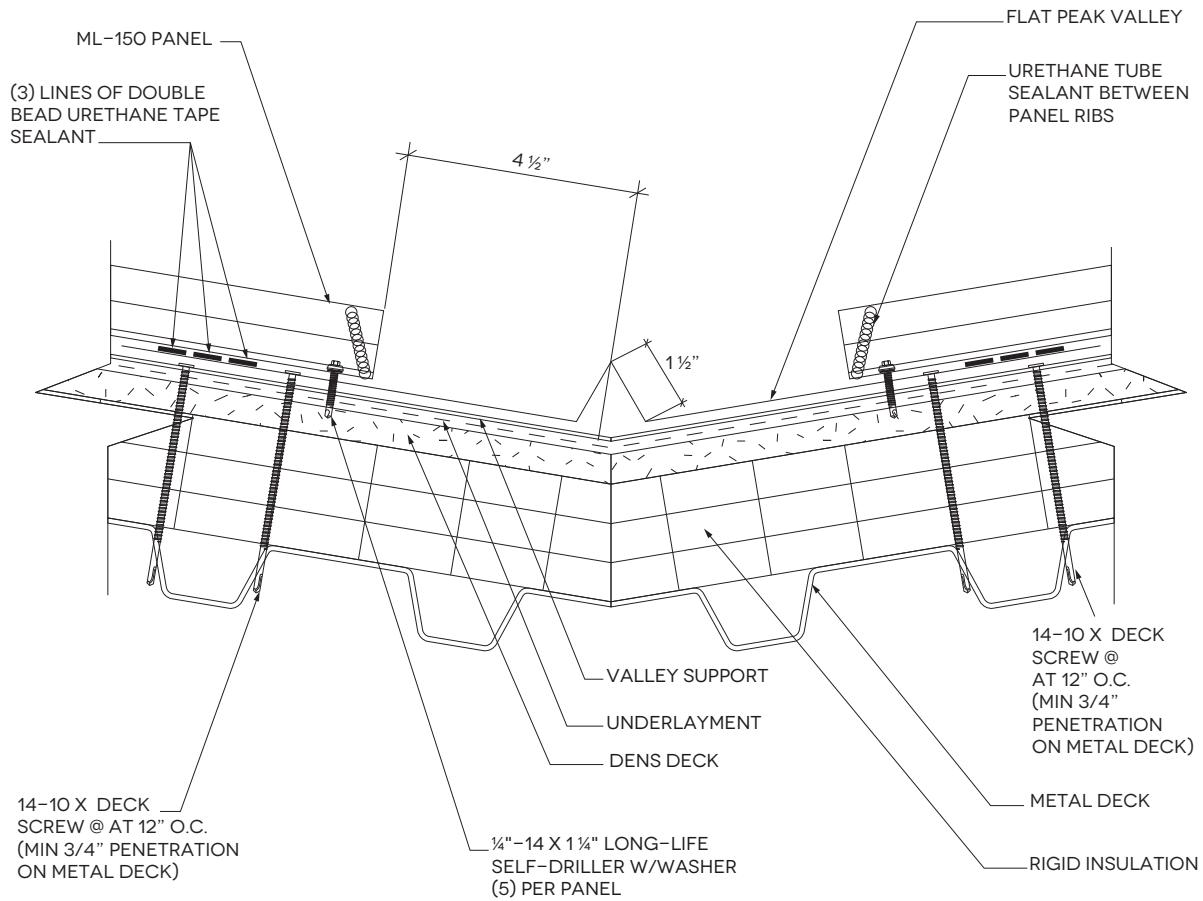

TYPICAL SCREW SEQUENCE AT VALLEY

Installation

PIPE PENETRATION

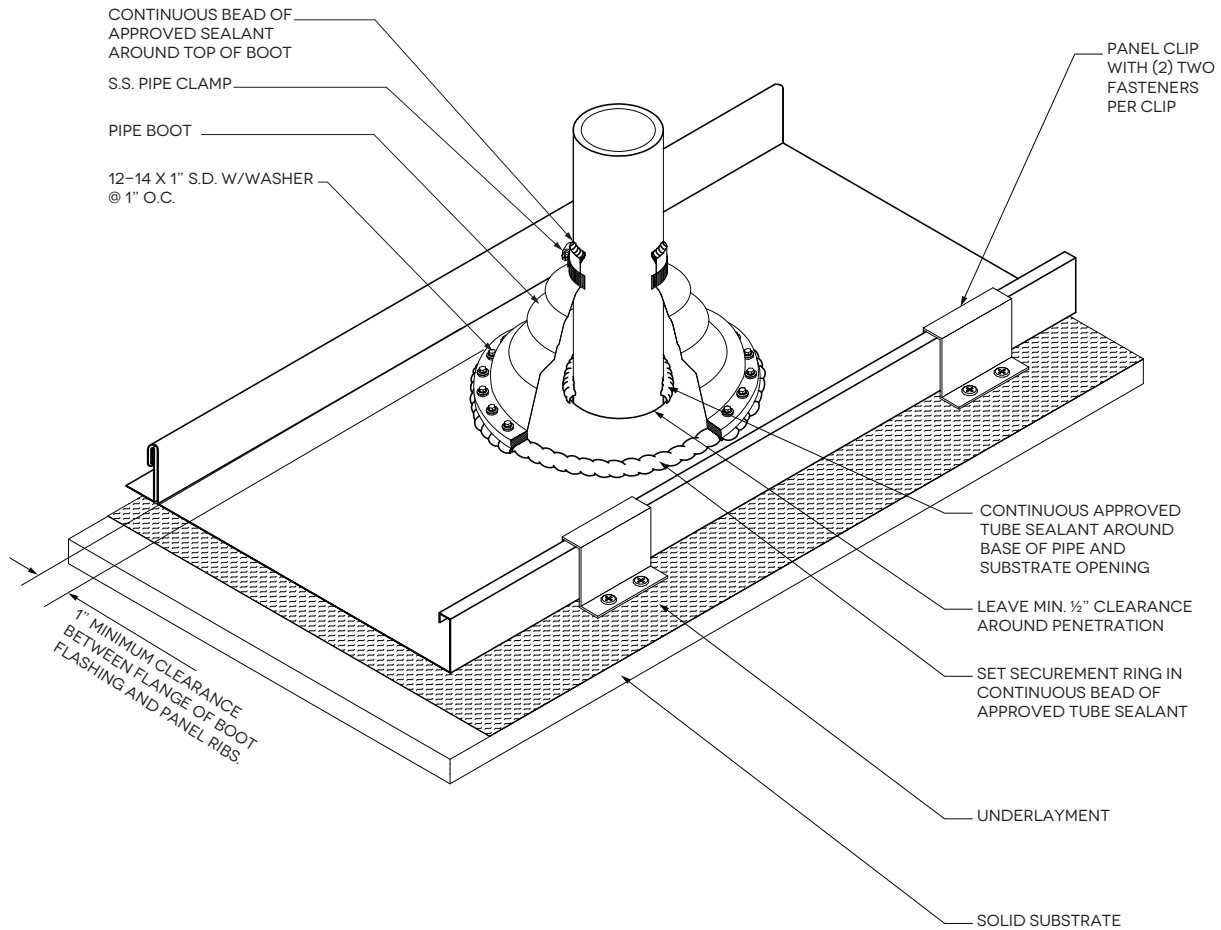

INCORRECT PIPE INSTALLATION

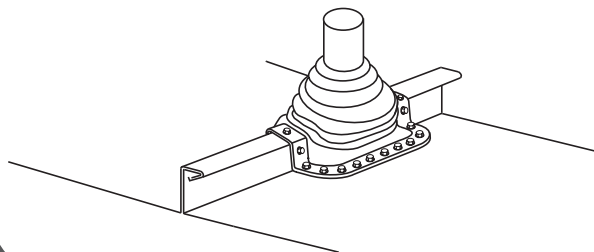

WARNING

INCORRECT PIPE INSTALLATION WILL VOID THE WEATHER-TIGHTNESS WARRANTY AND COMPROMISE ROOF PERFORMANCE. POTENTIAL LEAKS RESULTING FROM IMPROPER INSTALLATION CAN LEAD TO EXTENSIVE DAMAGE TO THE BUILDING. PLEASE ENSURE THAT ALL PIPES ARE INSTALLED CORRECTLY TO MAINTAIN THE INTEGRITY OF THE ROOF SYSTEM.

Installation

PIPE PENETRATION THROUGH PANEL RIB

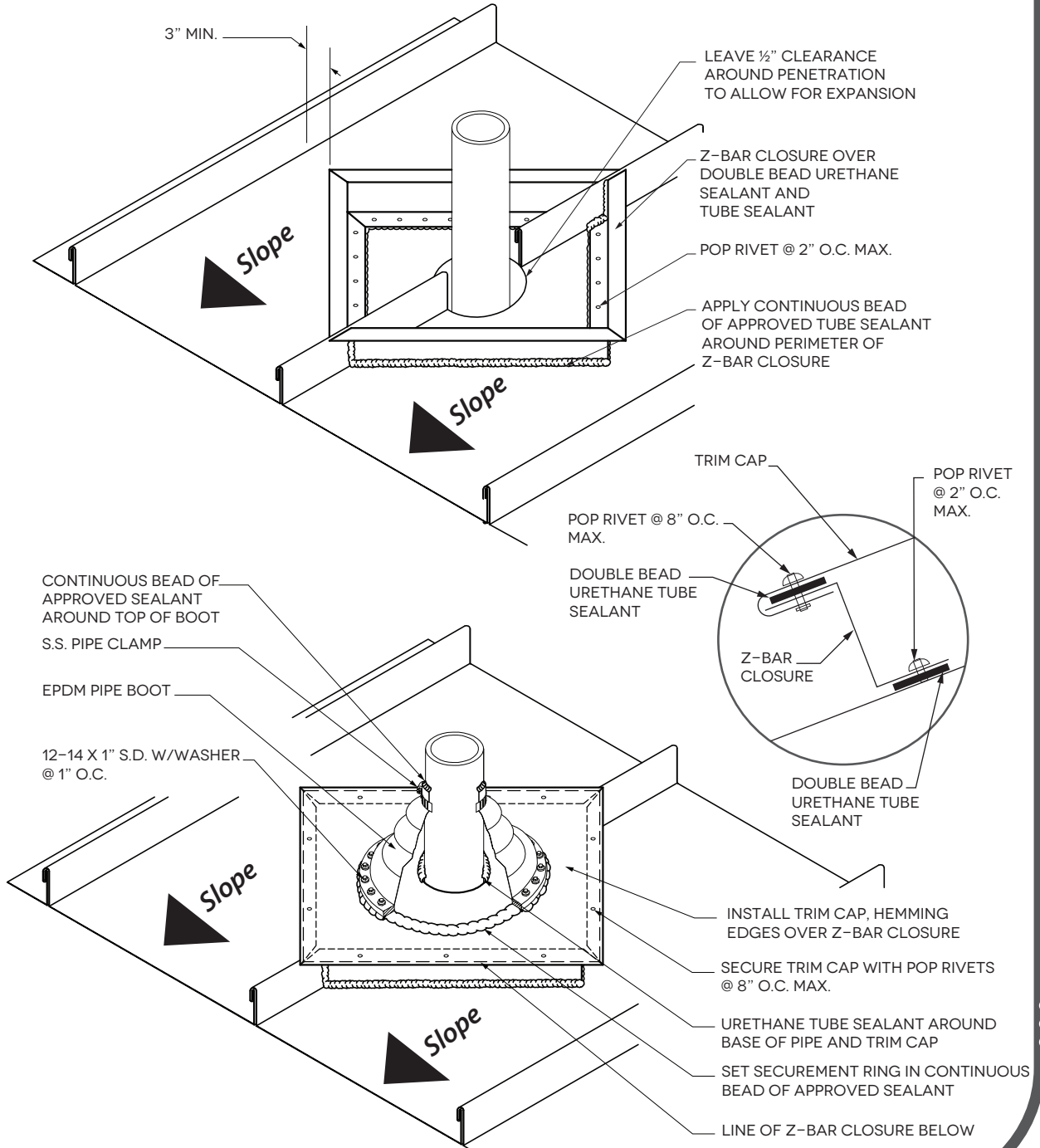

Installation

CURB DETAILS

STEP 1

INSTALL PANEL
AROUND THE CURBS

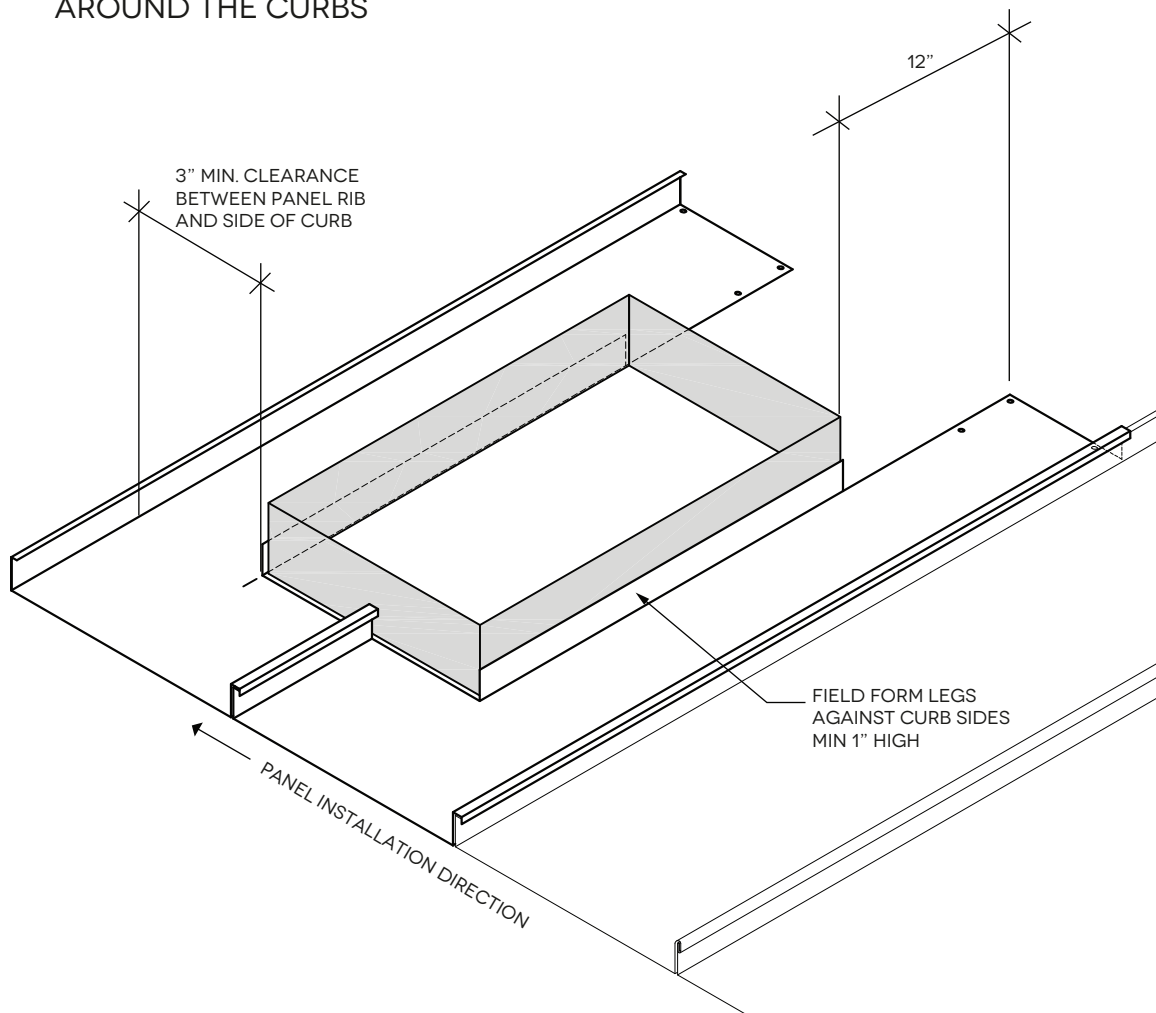

Installation

CURB DETAILS

STEP 2

APPLY Z-BAR CLOSURE
OVER DOUBLE BEAD
URETHANE TAPE SEALANT

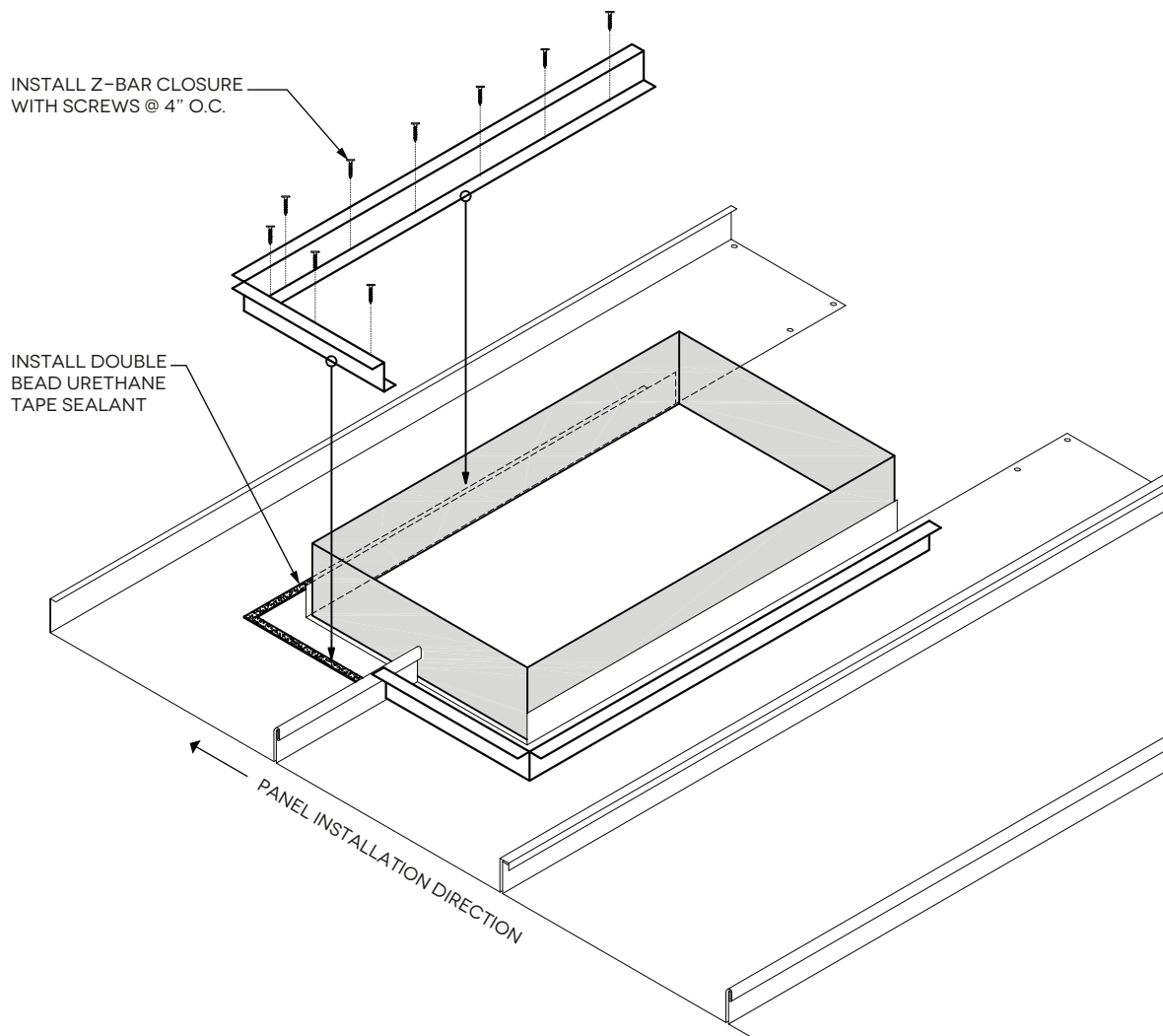

Installation

CURB DETAILS

STEP 3

INSTALL SIDE WALL AND
HIGH WALL FLASHING A
TOP OF Z-BAR CLOSURE

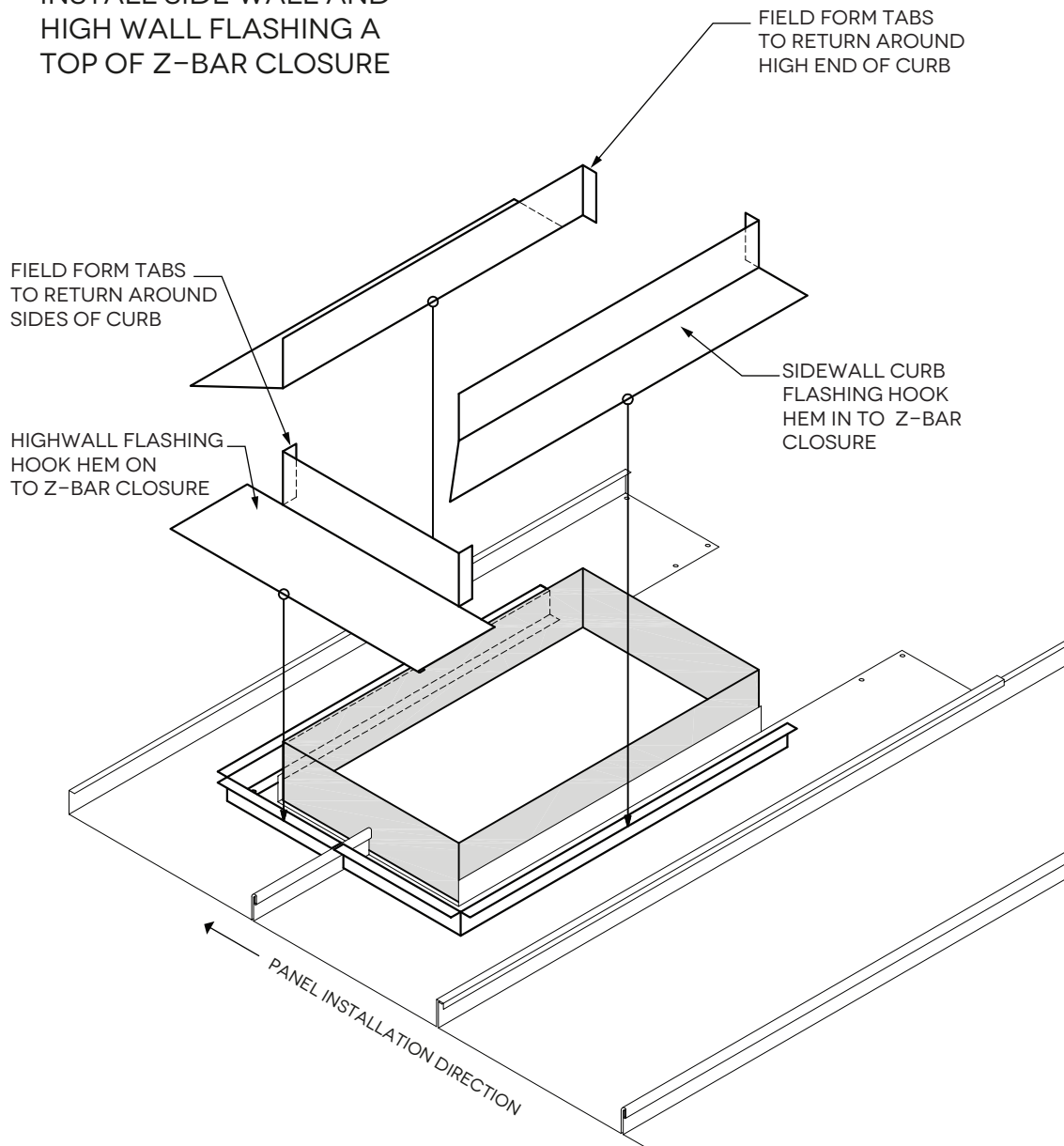

Installation

CURB DETAILS

STEP 4

INSTALL LOW WALL FLASHING

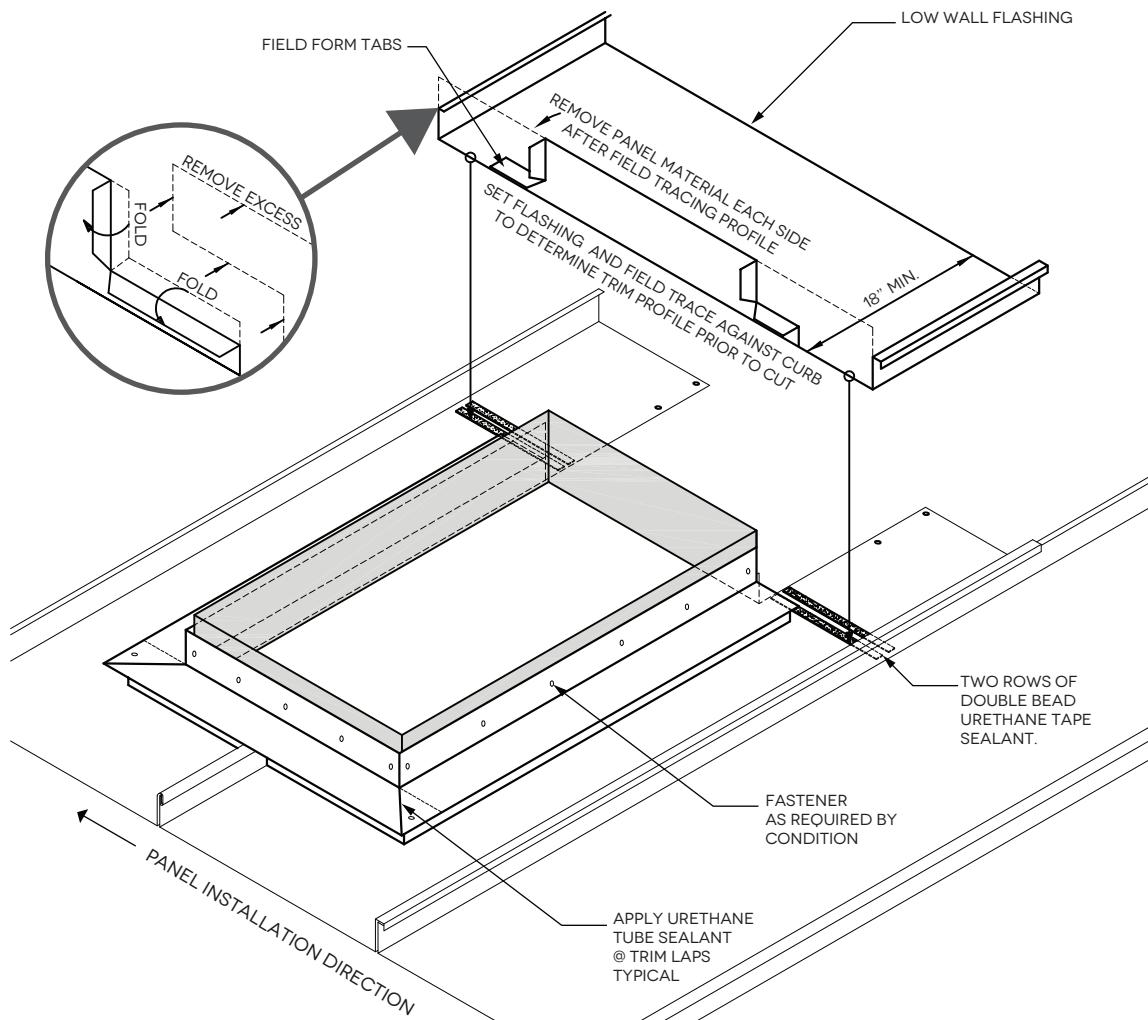

STEP 5

**INSTALL CLEAT AND
 PREPARE FOR UPPER
 PANEL INSTALLATION**

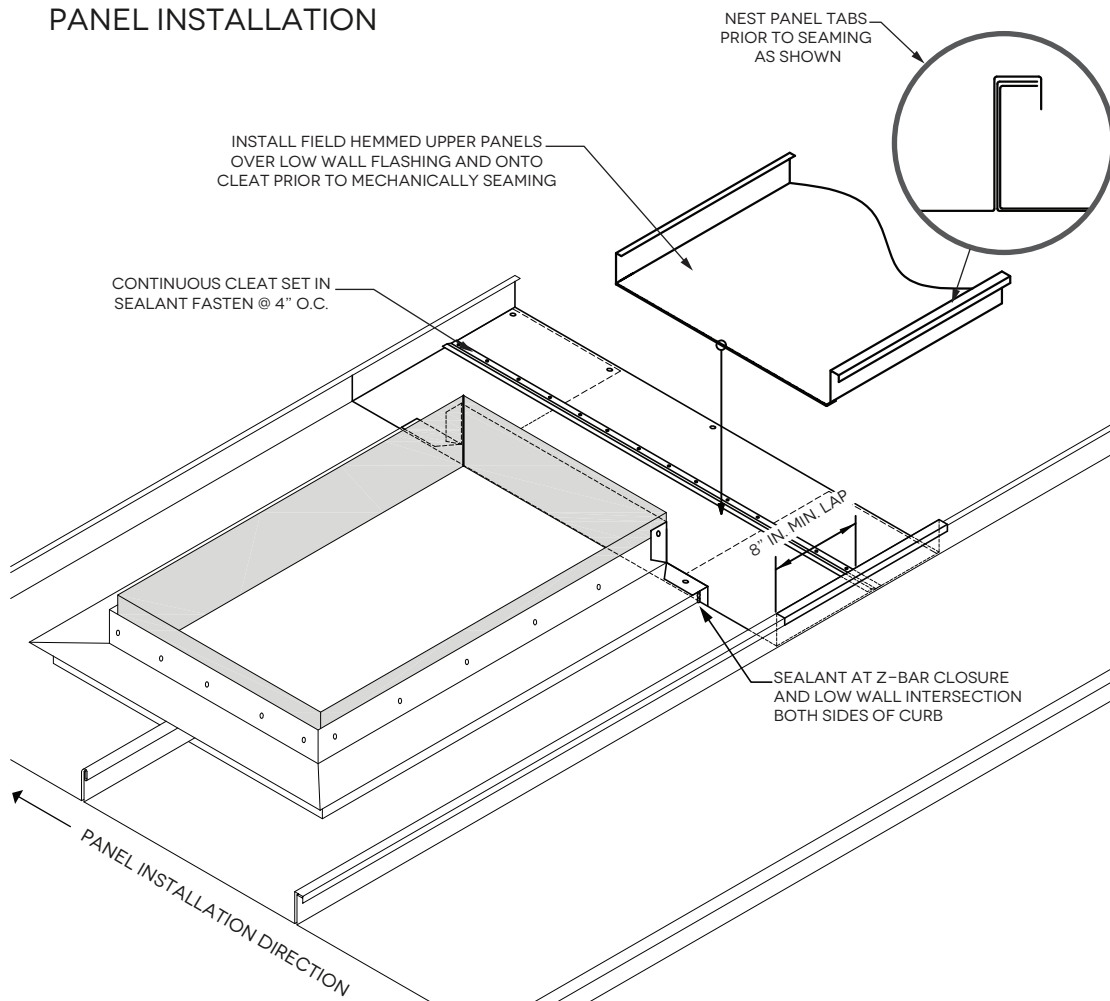

Installation

CURB DETAILS

STEP 6

INSTALL PANEL ABOVE CURB
SEAL AND FASTEN AS
REQUIRED

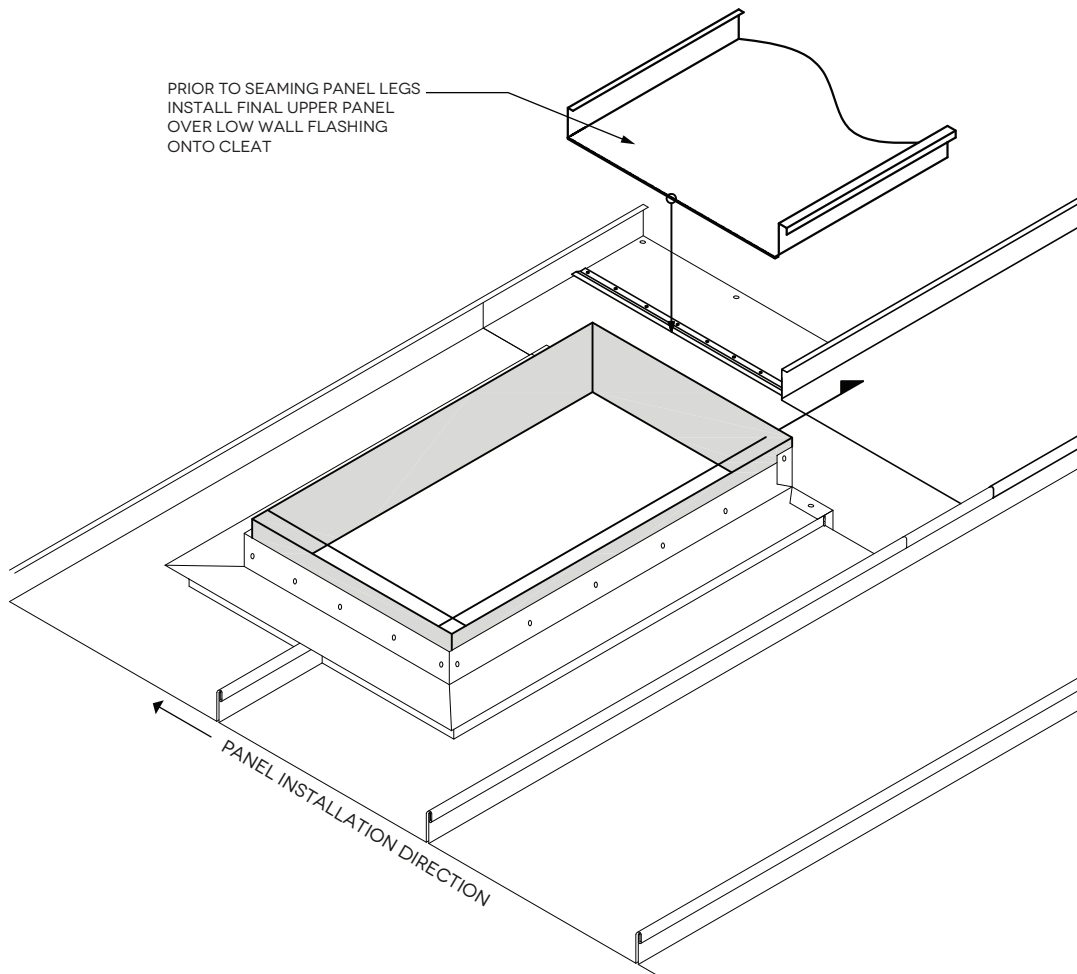

ML-150

1.5 MECHANICAL LOCK



SAN ANTONIO 2707 Castroville Rd • San Antonio, TX 78237 • (210) 227-7276 • Fax (210) 227-0329
MCALLEN 2221 Austin Ave • McAllen, TX 78501 • (956) 627-2966 • Fax (956) 627-0918
DALLAS 11569 Goodnight Lane • Dallas, TX 75229 • (972) 331 6800 • Fax (972) 331 6803
HOUSTON 6460 Langfield Road • Houston, TX 77092 • (713) 944-4480 • Fax (713) 944-4430

www.saqualitymetals.com